

UL 83

Thermoplastic-Insulated Wires  
and Cables



Underwriters Laboratories Inc. (UL)  
333 Pfingsten Road  
Northbrook, IL 60062-2096

UL Standard for Safety for Thermoplastic-Insulated Wires and Cables, UL 83

Fourteenth Edition, Dated February 15, 2008

**Summary of Topics:**

***This New Edition of ANSI/UL 83 Covers Revisions to Test Methods Based on Publication of UL 2556 and Other General, Construction, Performance, and Marking Requirements Revisions***

The following table lists the future effective date with corresponding text references.

Future Effective Date	References
February 15, 2009	Paragraphs 4.1.4.3, 4.4, and 7.2.4

The new requirements are substantially in accordance with UL's Proposal(s) on this subject dated April 6, 2007 and November 16, 2007.

As indicated on the title page (page 1), this UL Standard for Safety is an American National Standard. Attention is directed to the note on the title page of this Standard outlining the procedures to be followed to retain the approved text of this ANSI/UL Standard.

As indicated on the title page (page1), this UL Standard for Safety has been adopted by the Department of Defense.

The UL Foreword is no longer located within the UL Standard. For information concerning the use and application of the requirements contained in this Standard, the current version of the UL Foreword is located on ULStandardsInfoNet at: <http://ulstandardsinfo.net.ul.com/ulforeword.html>

The master for this Standard at UL's Northbrook Office is the official document insofar as it relates to a UL service and the compliance of a product with respect to the requirements for that product and service, or if there are questions regarding the accuracy of this Standard.

UL's Standards for Safety are copyrighted by UL. Neither a printed copy of a Standard, nor the distribution diskette for a Standard-on-Diskette and the file for the Standard on the distribution diskette should be altered in any way. All of UL's Standards and all copyrights, ownerships, and rights regarding those Standards shall remain the sole and exclusive property of UL.

All rights reserved. No part of this publication may be reproduced, stored in a retrieval system, or transmitted in any form by any means, electronic, mechanical photocopying, recording, or otherwise without prior permission of UL.

Revisions of UL Standards for Safety are issued from time to time. A UL Standard for Safety is current only if it incorporates the most recently adopted revisions.

UL provides this Standard "as is" without warranty of any kind, either expressed or implied, including but not limited to, the implied warranties of merchantability or fitness for any purpose.

In no event will UL be liable for any special, incidental, consequential, indirect or similar damages, including loss of profits, lost savings, loss of data, or any other damages arising out of the use of or the inability to use this Standard, even if UL or an authorized UL representative has been advised of the possibility of such damage. In no event shall UL's liability for any damage ever exceed the price paid for this Standard, regardless of the form of the claim.

UL will attempt to answer support requests concerning electronic versions of its Standards. However, this support service is offered on a reasonable efforts basis only, and UL may not be able to resolve every support request. UL supports the electronic versions of its Standards only if they are used under the conditions and operating systems for which it is intended. UL's support policies may change from time-to-time without notification.

UL reserves the right to change the format, presentation, file types and formats, delivery methods and formats, and the like of both its printed and electronic Standards without prior notice.

Purchasers of the electronic versions of UL's Standards for Safety agree to defend, indemnify, and hold UL harmless from and against any loss, expense, liability, damage, claim, or judgement (including reasonable attorney's fees) resulting from any error or deviation introduced while purchaser is storing an electronic Standard on the purchaser's computer system.

If a single-user version electronic Standard was purchased, one copy of this Standard may be stored on the hard disk of a single personal computer, or on a single LAN file-server or the permanent storage device of a multiple-user computer in such a manner that this Standard may only be accessed by one user at a time and for which there is no possibility of multiple concurrent access.

If a multiple-user version electronic Standard was purchased, one copy of the Standard may be stored on a single LAN file-server, or on the permanent storage device of a multiple-user computer, or on an Intranet server. The number of concurrent users shall not exceed the number of users authorized.

Electronic Standards are intended for on-line use, such as for viewing the requirements of a Standard, conducting a word search, and the like. Only one copy of the Standard may be printed from each single-user version of an electronic Standard. Only one copy of the Standard may be printed for each authorized user of a multiple-user version of an electronic Standard. Because of differences in the computer/software/printer setup used by UL and those of electronic Standards purchasers, the printed copy obtained by a purchaser may not look exactly like the on-line screen view or the printed Standard.

An employee of an organization purchasing a UL Standard can make a copy of the page or pages being viewed for their own fair and/or practical internal use.

The requirements in this Standard are now in effect, except for those paragraphs, sections, tables, figures, and/or other elements of the Standard having future effective dates as indicated in the preface. The prior text for requirements that have been revised and that have a future effective date are located after the Standard, and are preceded by a "SUPERSEDED REQUIREMENTS" notice.

New product submittals made prior to a specified future effective date will be judged under all of the requirements in this Standard including those requirements with a specified future effective date, unless the applicant specifically requests that the product be judged under the current requirements. However, if the applicant elects this option, it should be noted that compliance with all the requirements in this Standard will be required as a condition of continued Listing and Follow-Up Services after the effective date, and understanding of this should be signified in writing.

This Standard consists of pages dated as shown in the following checklist:

Page	Date
1-132 .....	February 15, 2008
SR1-SR2 .....	February 15, 2008

No Text on This Page



Association of Standardization and Certification  
NMX-J-010-ANCE-2008  
Fourth Edition



Canadian Standards Association  
CSA C22.2 No. 75-08  
Ninth Edition



Underwriters Laboratories Inc.  
UL 83  
Fourteenth Edition

## Thermoplastic-Insulated Wires and Cables

February 15, 2008



ANSI/UL 83-2008

## **Commitment for Amendments**

This Standard is issued jointly by the Association of Standardization and Certification (ANCE), the Canadian Standards Association (CSA), and Underwriters Laboratories Inc. (UL). Comments or proposals for revisions on any part of the standard may be submitted to ANCE, CSA, or UL at any time. Revisions to this standard will be made only after processing according to the standards development procedures of ANCE, CSA, and UL. CSA and UL will issue revisions to this standard by means of a new edition or revised or additional pages bearing their date of issue. ANCE will incorporate the same revisions into a new edition of the standard bearing the same date of issue as the CSA and UL pages.

---

## **Copyright © 2008 ANCE**

Rights reserved in favor of ANCE.

---

**ISBN 1-55436-276-8**

**© 2008**

**Canadian Standards Association**

All rights reserved. No part of this publication may be reproduced in any form whatsoever without the prior permission of the publisher.

To purchase CSA Standards and related publications, visit CSA's Online Store at **[www.ShopCSA.ca](http://www.ShopCSA.ca)** or call toll-free 1-800-463-6727 or 416-747-4044.

---

## **Copyright © 2008 Underwriters Laboratories Inc.**

Revisions of this Standard will be made by issuing revised or additional pages bearing their date of issue. A UL Standard is current only if it incorporates the most recently adopted revisions, all of which are itemized on the transmittal notice that accompanies the latest set of revised requirements. Comments or proposals for revisions on any part of the Standard may be submitted to UL at any time. Proposals should be submitted via a Proposal Request in UL's On-Line Collaborative Standards Development System (CSDS) at <http://csds.ul.com>.

To purchase UL Standards, visit COMM 2000 at [http://www.comm-2000.com/help/how\\_to\\_order.aspx](http://www.comm-2000.com/help/how_to_order.aspx) or call toll-free 1-888-853-3503.

The most recent CSA designation of ANSI/UL 83 as an American National Standard (ANSI) occurred on February 7, 2008.

This ANSI/UL Standard for Safety, which consists of the Fourteenth edition, is under continuous maintenance, whereby each revision is ANSI approved upon publication.

The Department of Defense (DoD) has adopted UL 83 on February 27, 1984. The publication of revised pages or a new edition of this Standard will not invalidate the DoD adoption.

---



**CONTENTS**

<b>Preface</b> .....	<b>6</b>
1 Scope .....	8
2 Definitions .....	8
3 General .....	8
3.1 Units of measure .....	8
3.2 Reference publications .....	9
3.3 Summary of requirements .....	12
4 Construction .....	12
4.1 Conductors .....	12
4.2 Insulation .....	17
4.3 Nylon jacket .....	19
4.4 Assemblies that include thermoplastic-insulated single conductors .....	19
5 Test requirements .....	19
5.1 General .....	19
5.2 Conductor resistance .....	20
5.3 Tests on aluminum conductors .....	20
5.4 Short-term insulation resistance at elevated temperature in water .....	20
5.5 Long-term insulation resistance in water .....	21
5.6 Long-term insulation resistance in air for 90°C rated conductors .....	21
5.7 Capacitance and relative permittivity of wet rated ("W" type) wires .....	22
5.8 Flexibility at room temperature after aging .....	23
5.9 Heat shock .....	23
5.10 Cold bend and cold impact .....	23
5.11 Deformation .....	24
5.12 Flame and smoke .....	24
5.13 Weather resistance (optional) .....	27
5.14 Oil resistance (optional) .....	28
5.15 Gasoline and oil resistance (optional) .....	28
5.16 Abrasion resistance (nylon-covered types or insulations other than PVC) .....	29
5.17 Crush resistance (nylon-covered types or insulations other than PVC) .....	29
5.18 Impact resistance (nylon-covered types or insulations other than PVC) .....	29
5.19 Durability of ink printing .....	29
5.20 Color coating .....	29
5.21 Long-term aging of insulation .....	30
5.22 A-C spark test .....	30
5.23 Dielectric voltage-withstand in water .....	30
5.24 Insulation resistance in water at 15°C .....	31
5.25 Electrical continuity .....	31
6 Marking .....	31
6.1 Marking on product .....	31
6.2 Marking on package .....	34
6.3 Month and year of manufacture .....	35
7 Deep-well submersible water pump cable .....	35
7.1 General .....	35
7.2 Construction .....	35
7.3 Marking .....	37
7.4 Tests .....	38
8 Test methods .....	39
8.1 General .....	39

8.2 Flame .....	40
-----------------	----

## Tables

## Figures

## Graphs

### Annex A (informative) Wire Type and Electrical Code Cross-Reference and Summary of Applications

### Annex B (normative for Mexico) Multiple-Conductor Thermoplastic-Insulated and -Jacketed Cables

B1 Scope .....	117
B1.1 General .....	117
B1.2 Single conductors .....	117
B2 Lay of cabled conductors .....	117
B3 Equipment-grounding conductor .....	118
B4 Conductor identification .....	118
B4.1 Color of insulated grounding conductor .....	118
B4.2 Identification of ungrounded (phase) conductor(s) .....	118
B4.3 Identification of grounded conductor(s) .....	118
B5 Fillers .....	118
B6 Jacket separators .....	118
B7 Jackets .....	118
B7.1 General .....	118
B7.2 Jacket thickness .....	119
B8 Marking .....	119
B8.1 Marking on product .....	119
B8.2 Marking on package .....	119

### Annex C (informative) Summary of Requirements

### Annex D (normative) Chemical Composition of Recognized ACM or AA 8000 Series Aluminum Alloy Conductor Materials

### Annex E (normative) Copper-Clad Aluminum Conductors

E1 General .....	126
E2 Sizes and stranding .....	126
E3 Conductor resistance .....	126
E4 Physical properties .....	126
E5 Marking requirements .....	126

**Annex F (informative) Metric Sizes**

**Annex G (informative) Evaluation of Materials Having Characteristics Differing from Those in Table 11**

**Annex H (informative) French and Spanish Translations and Markings**

H1 General .....	132
H2 Markings on wire .....	132
H3 Markings on packaging .....	132

## Preface

This is the harmonized ANCE, CSA, and UL Standard for Thermoplastic-Insulated Wires and Cables. It is the fourth edition of NMX-J-010-ANCE, the ninth edition of CSA-C22.2 No. 75, and the fourteenth edition of UL 83. This edition of CSA-C22.2 No. 75 supersedes the previous edition published in 2003. This edition of UL 83 supersedes the previous edition published in 2003.

This harmonized standard was prepared by the Association of Standardization and Certification (ANCE), the Canadian Standards Association (CSA), and Underwriters Laboratories Inc. (UL). The efforts and support of the Technical Harmonization Committee for Electrical Wires and Cables, of the Council on the Harmonization of Electrotechnical Standards of the Nations of the Americas (CANENA), are gratefully acknowledged.

This standard is considered suitable for use for conformity assessment within the stated scope of the standard.

This standard was reviewed by the CSA Subcommittee on Fixed Installation Wires and Cables, under the jurisdiction of the CSA Technical Committee on Wiring Products and the CSA Strategic Steering Committee on Requirements for Electrical Safety, and has been formally approved by the CSA Technical Committee. This standard was reviewed and approved by the Committee de Normalizacion of ANCE (CONANCE). This standard was reviewed by UL's Standards Technical Panel (STP) for Power Cables, STP 83.

This standard has been approved by the American National Standards Institute (ANSI) as an American National Standard.

A UL standard is current only if it incorporates the most recently adopted revisions, all of which are itemized on the transmittal notice that accompanies the latest set of revised requirements.

Where reference is made to a specific number of specimens to be tested, the specified number is to be considered a minimum quantity.

*Note: Although the intended primary application of this standard is stated in its scope, it is important to note that it remains the responsibility of the users of the standard to judge its suitability for their particular purpose.*

### Level of Harmonization

This standard uses the IEC format but is not based on, nor is it to be considered equivalent to, an IEC standard. This standard is published as an equivalent standard for ANCE, CSA, and UL.

An equivalent standard is a standard that is substantially the same in technical content, except as follows: Technical national differences are allowed for codes and governmental regulations as well as those recognized as being in accordance with NAFTA Article 905, for example, because of fundamental climatic, geographical, technological, or infrastructural factors, scientific justification, or the level of protection that the country considers appropriate. Presentation is word for word except for editorial changes.

### Reasons for Differences to IEC

This standard provides requirements for insulated wires and cables for use in accordance with the electrical installation codes of Canada, Mexico, and the United States. At present there is no IEC standard for wires and cables for use in accordance with these codes. Therefore, this standard does not employ any IEC standard for base requirements.

**Interpretations**

The interpretation by the standards development organization of an identical or equivalent standard is based on the literal text to determine compliance with the standard in accordance with the procedural rules of the standards development organization. If more than one interpretation of the literal text has been identified, a revision is to be proposed as soon as possible to each of the standards development organizations to more accurately reflect the intent.

**ANCE effective date**

The effective date for ANCE will be announced through the Diario Oficial de la Federación (Official Gazette) and is indicated on the cover page.

**CSA effective date**

The effective date for CSA International will be announced through CSA Informs or a CSA certification notice.

**UL effective date**

As of February 15, 2008, all products Listed or Recognized by UL must comply with the requirements in this standard except for clauses, figures, and tables in the following list, which are effective February 15, 2009:

Clauses 4.1.4.3, 4.4, and 7.2.4.

Between February 15, 2008 and February 15, 2009, new product submittals to UL may be evaluated under all requirements in this standard or, if requested in writing, evaluated under presently effective requirements only.

A UL effective date is one established by Underwriters Laboratories Inc. and is not part of the ANSI approved standard.

# Thermoplastic-Insulated Wires and Cables

## 1 Scope

1.1 This Standard specifies the requirements for 600 V, single-conductor, thermoplastic-insulated wires and cables, for use as follows:

- a) In Canada, in accordance with CSA C22.1, *Canadian Electrical Code (CEC), Part I*;
- b) In Mexico, in accordance with NOM-001-SEDE, *Standard for Electrical Installations*; and
- c) In the United States, in accordance with ANSI/NFPA 70, *National Electrical Code (NEC)*.

**Note:** See Annex A for the complete list of wire types covered by this Standard and the specific electrical codes for which they are intended.

1.2 This Standard also specifies the requirements for submersible-pump cables, with or without jackets (see Clause 7). No type-letter designations are assigned to these cables.

1.3 In Mexico, the requirements for multiple-conductor thermoplastic-insulated and -jacketed cables rated 600 V are specified in Annex B.

In Canada and the United States, requirements for multiple-conductor thermoplastic-insulated and -jacketed cables rated 600 V are covered in other standards.

1.4 Products for which this Standard provides requirements may have applications not described in the electrical codes listed in Clause 1.1.

## 2 Definitions

2.1 The following definitions apply in this Standard:

**Equipment-grounding conductor** – a conductor that is defined in Mexico, in NOM-001-SEDE, and in the United States, in the *NEC*, as “Grounding Conductor, Equipment”, and in Canada, in the *CEC*, as “Bonding conductor”.

**PVC** – a thermoplastic compound whose characteristic constituent is polyvinyl chloride or a copolymer of vinyl chloride and vinyl acetate.

**Thermoplastic** – a polymeric material that can repeatedly be softened by heating and hardened by cooling and that in the softened state can be shaped through the application of force.

## 3 General

### 3.1 Units of measure

The unit of measure shall be SI. If a value for measurement is followed by a value in other units in parentheses, the second value represents a direct conversion or an alternative value. Except for conductor size, the first stated value is the requirement.

### 3.2 Reference publications

This Standard refers to the following publications and where such reference is made to ANCE, CSA, or UL Standards, it shall be to the latest edition and all amendments published thereto. Where such reference is made to other publications, it shall be to the edition listed below.

#### ANCE Standards

NOM-001-SEDE,  
*Standard for Electrical Installations*

NMX-J-008-ANCE,  
*Tinned Soft or Annealed Copper Wire for Electrical Purposes – Specifications*

NMX-J-012-ANCE,  
*Wires and Cables – Concentric Lay Stranded Copper Conductors for Electrical Purposes – Specifications*

NMX-J-013-ANCE,  
*Wires and Cables – Rope Lay Stranded Copper Conductors Having Concentric – Stranded Members for Electrical Conductors – Specifications*

NMX-J-014-ANCE,  
*Wires and Cables – Rope Lay Stranded Copper Conductors Having Bunch Stranded Members for Electrical Applications*

NMX-J-032-ANCE,  
*Wires and Cables – Concentric Lay Stranded Aluminum 1350 Cable, for Electrical Purposes – Specifications*

NMX-J-036-ANCE,  
*Soft or Annealed Copper Wire for Electrical Purposes – Specifications*

NMX-J-040-ANCE,  
*Determination of Moisture Absorption in Insulations and Jackets of Electrical Conductors – Test Method*

NMX-J-066-ANCE,  
*Determination of Diameters on Electrical Conductors – Test Method*

NMX-J-177-ANCE,  
*Determination of Thickness of Semiconductive Shielding, Insulations, and Jackets of Electrical Conductors – Test Method*

NMX-J-178-ANCE,  
*Ultimate Strength and Elongation of Insulation, Semiconductive Shielding and Jackets of Electrical Conductors – Test Method*

NMX-J-186-ANCE,  
*Accelerated Aging in Forced-Convection Ovens of Semiconductive Shielding, Insulations and Jackets of Electrical Conductors – Test Method*

NMX-J-189-ANCE,  
*Electrical Products – Wires and Cables – Room Temperature Flexibility Test for PVC Insulated Electrical Conductors – Test Method*

NMX-J-190-ANCE,  
*Heat Shock Resistance of PVC Insulations and Protective Coverings of Electrical Conductors – Test Method*

NMX-J-191-ANCE,  
*Heat Distortion of Semiconductive Shielding, Insulations and Protective Coverings of Electrical Conductors – Test Method*

NMX-J-192-ANCE,  
*Flame Test on Electrical Wires – Test Method*

NMX-J-193-ANCE,  
*Cold Bend of Thermoplastic Insulation and Protective Jackets, Used on Insulated Wire and Cable – Test Method*

NMX-J-194-ANCE,  
*Wires and Cables – Oil Immersion Aging for Insulations and Jackets of Electrical Conductors – Test Method*

NMX-J-212-ANCE,  
*Electrical Resistance, Resistivity and Conductivity – Test Method*

NMX-J-293-ANCE,  
*Wires and Cables – Alternating Current and Direct Current Dielectric Voltage Withstand – Test Method*

NMX-J-294-ANCE,  
*Insulation Resistance – Test Method*

NMX-J-312-ANCE,  
*Rupture Strength and Elongation by Strain of Wires for Electrical Conductors – Test Method*

NMX-J-417-ANCE,  
*Wires and Cables – Convection Laboratory Ovens for Evaluation of Electrical Insulation – Specifications and Test Methods*

NMX-J-473-ANCE,  
*Wires and Cables – Spark Test – Test Method*

NMX-J-498-ANCE,  
*Wires and Cables – Vertical Tray Flame Test – Test Method*

NMX-J-556-ANCE,  
*Wire and Cable Test Methods*

### **CSA Standards**

C22.1-06,  
*Canadian Electrical Code, Part I*

C22.2 No. 0.3-96(R2005),  
*Test Methods for Electrical Wires and Cables*



CAN/CSA-C22.2 No. 131-M89(R2004),  
*Type TECK 90 Cable*

C22.2 No. 230-M1988(R2004),  
*Tray Cables*

C22.2 No. 239-97(R2001),  
*Control and Instrumentation Cables*

C22.2 No. 2556-05,  
*Wire and Cable Test Methods*

#### **UL Standards**

UL 1581  
*Reference Standard for Electrical Wires, Cables, and Flexible Cords*

UL 1685  
*Vertical-Tray Fire-Propagation and Smoke-Release Test for Electrical and Optical-Fiber Cables*

UL 2556  
*Wire and Cable Test Methods*

#### **ASTM\* Standards**

A 29/A 29M-05,  
*Standard Specification for Steel Bars, Carbon and Alloy, Hot-Wrought and Cold Finished, General Requirements for*

B 3-01,  
*Standard Specification for Soft or Annealed Copper Wire*

B 33-04,  
*Standard Specification for Tinned Soft or Annealed Copper Wire for Electrical Purposes*

B172-01a(2007)e1,  
*Standard Specification for Rope-Lay-Stranded Copper Conductors Having Bunch-Stranded Members, for Electrical Conductors*

B173-01a(2007)e1,  
*Standard Specification for Rope-Lay-Stranded Copper Conductors Having Concentric-Stranded Members, for Electrical Conductors*

B231/B231M-04,  
*Standard Specification for Concentric-Lay-Stranded Aluminum 1350 Conductors*

B835-04,  
*Standard Specification for Compact Round Stranded Copper Conductors Using Single Input Wire Construction*

B836-00(2005),  
*Standard Specification for Compact Round Stranded Aluminum Conductors Using Single Input Wire Construction*

**IEC† Standards**

60228 (2004-11),  
*Conductors of insulated cables*

**IEEE‡ Standards**

1202-2006,  
*IEEE Standard for Flame-Propagation Testing of Wire and Cable*

**NFPA§ Publication**

NFPA 70-2005,  
*National Electrical Code*

*\*American Society for Testing and Materials.*

*†International Electrotechnical Commission.*

*‡Institute of Electrical and Electronics Engineers.*

*§National Fire Protection Association.*

**3.3 Summary of requirements**

As a guide to users of this Standard, a summary of requirements is provided in Annex C.

**4 Construction****4.1 Conductors****4.1.1 General**

Circuit and equipment-grounding conductors shall be of either copper, copper-clad aluminum, or aluminum.

#### 4.1.2 Aluminum conductors

In Canada and the United States, the following applies: all conductors shall be of aluminum conductor material (ACM), AA 8000 series alloy.

Annex D provides the chemical composition of recognized aluminum alloy conductor materials.

In Mexico, the following applies: aluminum conductors shall not be used in thermoplastic-insulated wires and cables in accordance with NOM-001-SEDE.

#### 4.1.3 Copper-clad aluminum conductors

In the United States, the following applies: the requirements of Annex E shall apply to solid conductors or the individual wires of stranded conductors prior to stranding.

In Canada and Mexico, copper-clad aluminum conductors shall not be used in thermoplastic-insulated wires and cables.

#### 4.1.4 Copper conductors

##### 4.1.4.1 General

The requirements of Clauses 4.1.4.2 or 4.1.4.3 shall apply to solid conductors or the individual wires of stranded conductors prior to stranding.

##### 4.1.4.2 Bare copper conductors

Each wire in a bare copper conductor shall comply with the requirements of ASTM B 3 or NMX-J-036-ANCE.

##### 4.1.4.3 Tin-coated copper conductors

Each wire in a tin-coated conductor shall comply with the requirements of ASTM B 33 or NMX-J-008-ANCE. Overcoating of 2.08 mm<sup>2</sup> (14 AWG), 3.31 mm<sup>2</sup> (12 AWG), and 5.26 mm<sup>2</sup> (10 AWG) stranded copper conductor with a layer of tin shall be optional.

## 4.1.5 Sizes and stranding

### 4.1.5.1 Sizes

Conductors shall be as shown in Table 1.

**Note:** IEC conductor sizes are not recognized in the CEC, NEC, or NOM-001-SEDE; however, these sizes may be required for wires and cables intended for use outside of the codes. As a guide to users of this Standard, information on IEC conductors is provided in Annex F.

### 4.1.5.2 Stranding

#### 4.1.5.2.1 General

The minimum number of wires (strands) in a conductor shall be in accordance with Table 2.

Copper strands smaller than 0.0127 mm<sup>2</sup> (36 AWG) and aluminum strands smaller than 0.324 mm<sup>2</sup> (22 AWG) shall not be used. A compact- stranded conductor shall not be segmented.

#### 4.1.5.2.2 Compact

A compact-stranded conductor shall be a round conductor consisting of a central core surrounded by one or more layers of helically laid wires, and formed into a smooth outermost layer by rolling, drawing, or other means. The lay length of every layer shall be not less than 8 times nor more than 16 times the outside diameter of the completed conductor, except that for sizes 33.6 mm<sup>2</sup> (2 AWG) and smaller, the maximum lay length shall be 17.5 times the outside diameter. The direction of lay of the outermost layer shall be left-hand, and it shall be reversed or unidirectional/unilay in successive layers.

#### 4.1.5.2.3 Compressed

A compressed-stranded conductor shall be a round conductor consisting of a central core surrounded by one or more layers of helically laid wires with either the direction of lay reversed in successive layers or unilay or unidirectional lay. The direction of lay of the outer layer shall be left-hand in all cases. The strands of one or more layers shall be slightly compressed by rolling, drawing, or other means to change the originally round strands to various shapes that achieve filling of some of the spaces originally present between the strands.

#### 4.1.5.2.4 Assembly of strands

A 19-wire combination round-wire unilay stranded conductor shall be round and shall consist of a straight central wire, an inner layer of six wires of the same diameter as the central wire, and an outer layer consisting of six wires with the same diameter as the central wire alternated with six wires with a diameter of 0.732 times the diameter of the central wire. No particular assembly of the individual wires of any other stranded conductor shall be required. However, simple bunching (untwisted strands) shall not be used. The length of lay of the strands in a bunch-stranded conductor twisted as a single bunch shall not be greater than as indicated in Table 3. The direction of lay of the strands in a bunch-stranded conductor shall be left-hand.

#### 4.1.5.2.5 Length and direction of lay

Every stranded conductor other than a compact-stranded conductor or a bunch-stranded conductor twisted as a single bunch shall comply with the following:

- a) The direction of lay of the strands, members, or ropes in a 13.3 – 1010 mm<sup>2</sup> (6 AWG – 2000 kcmil) conductor, other than a combination unilay or a compressed unilay or compressed unidirectional lay conductor, shall be reversed in successive layers. Rope-lay conductors with bunch-stranded or concentric-stranded members shall be either unidirectional or reversed. All unidirectional lays and the outer layer of reversed lays shall be in the left-hand direction.
- b) For a bunch-stranded member of a rope-lay-stranded conductor in which the members are formed into rope-stranded components that are then cabled into the final conductor, the length of lay of the individual members within each component shall not be more than 30 times the outside diameter of one of those members.
- c) For a concentric-stranded member of a rope-lay-stranded conductor, the length of lay of the individual strands in a member shall be 8 – 16 times the outside diameter of the member. The direction of lay of the strands in each member shall be reversed in successive layers of the member.
- d) The length of lay of the strands in both layers of a 19-wire combination round-wire unilay-stranded copper or aluminum conductor shall be 8 – 16 times the outside diameter of the completed conductor. Otherwise, the length of lay of the strands in every layer of a concentric-lay-stranded conductor consisting of fewer than 37 strands shall be 8 – 16 times the outside diameter of the conductor.
- e) The length of lay of the strands in the outer two layers of a concentric-lay-stranded conductor consisting of 37 or more strands shall be 8 – 16 times the outside diameter of the conductor.
- f) The length of lay of the members or ropes in the outer layer of a rope-lay-stranded conductor shall be 8 – 16 times the outside diameter of that layer.

#### 4.1.6 Diameter and cross-sectional area

4.1.6.1 The nominal diameters of solid and stranded conductors are shown in Tables 4 – 9. The minimum diameter for stranded conductors is 98 percent of the nominal. The maximum diameter is 101 percent of the nominal. The diameter shall be determined in accordance with the test, Conductor diameter, in UL 2556, CSA C22.2 No. 2556, or NMX-J-129-ANCE.

Conductor sizes in mm<sup>2</sup> (AWG/kcmil) covered by this Standard are shown in Table 4. The nominal cross-sectional area of a conductor identified in Table 4 is not a requirement.

The nominal cross-sectional area, if required, shall be determined in accordance with the test, Cross-sectional area, in UL 2556, CSA C22.2 No. 2556, or NMX-J-129-ANCE.

4.1.6.2 In the United States, the following applies: compressed unilay or compressed unidirectional lay copper conductors that are smaller in diameter than the requirement (0.98 x nominal in Table 6) for compressed concentric lay conductors shall be marked in accordance with Clause 6.1.6.

In Canada and Mexico, this requirement does not apply.

#### 4.1.7 Joints

4.1.7.1 A joint in a solid conductor or in one of the individual wires of a stranded conductor shall neither increase the diameter nor materially decrease the strength of the conductor or the individual wire. Not more than one of the wires in a stranded conductor of 19 wires or less, nor more than one of the wires in any given layer in a stranded conductor of more than 19 wires, shall be joined in any 0.3 m (1 ft) of conductor.

4.1.7.2 In a rope-lay-stranded conductor, which consists of a central core surrounded by one or more layers of stranded members (primary groups), each member shall be considered equivalent to a solid wire, and as such, shall be spliced as a unit. These joints shall not be any closer together than 2 lay lengths.

4.1.7.3 A joint shall be allowed in a Class B stranded 2.08 mm<sup>2</sup> (14 AWG), 3.31 mm<sup>2</sup> (12 AWG), or 5.26 mm<sup>2</sup> (10 AWG) insulated copper conductor intended to be used in a multiple-conductor cable, with an overall covering. The joint (butt splice) shall be made by machine brazing or welding the entire conductor such that the resulting solid section of the stranded conductor is no longer than 13 mm (0.50 inch). In addition, the joint shall not increase the diameter of the conductor, there shall be no sharp points, and the distance between joints in a single conductor shall not average less than 1000 m (3280 ft) in any finished length of that single insulated conductor. A joint (butt splice) shall be made before or after insulating and prior to further processing. Where joints (butt splices) are made after insulating, the insulation applied over the joint shall be of the same insulation material used throughout the length of the conductor, or of another insulating material that meets or exceeds the electrical, physical, and mechanical requirements of this Standard for the original insulating material. Joints in bare or insulated equipment-grounding conductors shall not be allowed. Insulated conductors with a joint (butt splice) shall not be surface marked with a type designation.

#### 4.1.8 Separator

A separator of suitable material between the conductor and the insulation shall be optional. The separator shall be of contrasting color to the conductor color, except that clear or green shall not be used. White-colored separator over aluminum conductors shall be optional. The separator and the other wire or cable components shall not have any deleterious effect on each other.

### 4.2 Insulation

#### 4.2.1 General

Conductors shall be insulated for their entire length with PVC or other thermoplastic material meeting all the requirements of this Standard. The insulation shall be applied directly over the conductor, or over the separator if provided, and shall fit tightly thereto. The insulation shall be free from pores, splinters, and other inhomogeneities visible without magnification to normal or corrected-to-normal vision.

If the insulation is applied in more than one layer, the interface between the layers shall be free of voids visible without magnification to normal or corrected-to-normal vision, and all layers shall be taken together for all measurements and tests.

#### 4.2.2 Repairs

Where a repair is made in the insulation, the insulation applied to the repaired section shall be equivalent to that removed, and the repaired section of the finished conductor shall comply with the same electrical and thickness requirements specified in this Standard.

#### 4.2.3 Colored insulation

4.2.3.1 When colored insulation is required, either the insulation shall be colored throughout its thickness or a thin colored coating of suitable material shall be applied to the surface of the insulation. The coating material shall not have an adverse effect on the properties of the insulation. If the coating is of an extruded type, it shall be considered as part of the insulation and shall comply with all requirements.

4.2.3.2 Polarity identification of circuit conductors other than the grounding or grounded conductor shall be provided by means of contrasting colors other than white, gray, or green; by ridges; by stripes; or by word printing. Grounded circuit conductors shall be colored white or gray or shall have three continuous white stripes on a background of other than green or green with yellow stripes. Longitudinal white stripes shall be spaced nominally 120 degrees apart. The equipment-grounding conductor shall be colored green or green with continuous or broken yellow stripes.

4.2.3.3 Stripes as specified in 4.2.3.2 shall be of even or varying width and shall occupy a total of 5 – 70 percent of the calculated circumference of the outer surface of the finished insulated conductor with no individual width less than 5 percent of that same circumference. The width shall be measured perpendicular to each stripe. Where broken stripes are appropriate, they shall consist of a series of identical marks and spaces, the length of each mark shall be at least 3 mm (1/8 inch), and the linear spacing between marks shall not be greater than 19 mm (3/4 inch).

#### 4.2.4 Thickness and centering

The average and minimum thickness of the insulation shall be as shown in Table 10. Compliance shall be determined in accordance with the test, Thickness, in UL 2556, CSA C22.2 No. 2556, or NMX-J-177-ANCE.

The insulation shall have a circular cross-section, with the insulation applied concentrically about the conductor and fitting tightly on the conductor or over any separator.

#### 4.2.5 Physical properties of insulation

##### 4.2.5.1 General

4.2.5.1.1 The tensile strength and ultimate elongation of PVC insulation, before and after aging, shall be as specified in Table 11.

##### 4.2.5.2 Test requirement

4.2.5.2.1 Compliance with Clause 4.2.5.1.1 shall be determined in accordance with the test, Physical properties (ultimate elongation and tensile strength), in UL 2556, CSA C22.2 No. 2556, or NMX-J-556-ANCE.

##### 4.2.5.3 Evaluation of alternative insulation materials for use in this Standard (see Annex G)

4.2.5.3.1 Alternative insulation materials for products shall be evaluated in accordance with the test, Dry temperature rating of new materials (long-term aging test), in UL 2556, CSA C22.2 No. 2556, or NMX-J-556-ANCE.

4.2.5.3.2 Materials having characteristics different from those specified in Table 11 shall be evaluated for the requested temperature rating in accordance with Clause 5.21. To be evaluated, materials shall have an initial absolute minimum tensile strength of not less than 6.8 MPa (1000 lbf/in<sup>2</sup>), and an absolute minimum elongation of 100 percent before aging.

4.2.5.3.3 The temperature rating and thickness of those materials having characteristics different from those specified in Table 11 shall be as required for the specific thermoplastic-insulated wire or cable type. The electrical, mechanical, and physical characteristics of the wire or cable using these materials shall be such that the materials meet the specified requirements for PVC for the temperature rating.

4.2.5.3.4 Insulation material complying with 4.2.5.3.2 shall then be evaluated to establish requirements for its specific physical properties in Table 12.



### 4.3 Nylon jacket

#### 4.3.1 General

Types THHN, THWN, TWN75, THWN-2, and T90 Nylon shall have a jacket of nylon extruded tightly over the insulation. The use of nylon jackets on other types to which this Standard applies shall be optional. Where utilized, nylon jackets shall comply with all applicable requirements. Jacket materials other than nylon meeting the requirements of this Standard shall be acceptable.

#### 4.3.2 Thickness

The minimum jacket thickness at any point shall be as shown in Table 13, and shall be measured in accordance with UL 1581, Section 240; CSA C22.2 No. 0.3, Clause 4.2.1; or NMX-J-177-ANCE.

### 4.4 Assemblies that include thermoplastic-insulated single conductors

When cabled into assemblies (length and direction of lay not specified), single-conductor wires that comply with the requirements in this Standard shall not be considered cables, and do not include overall coverings. An open, skeleton tape or wrap intended only to hold the assembly together shall be allowed. Such assemblies shall be allowed to include other single-conductor wires or cables not covered in this Standard. An assembly shall be without a bare or covered aluminum conductor, but a bare copper conductor – size is not specified – that is coated with tin, a lead-base alloy, or other metal shall be optional. A bare, coated copper conductor shall not be covered. The completed assembly shall meet the following requirements:

- a) Assemblies in which a bare, coated copper conductor is included shall be tested for dielectric voltage-withstand as indicated in Clause 5.23, except that immersion in water shall be for at least 1 h.
- b) Each assembly in which a bare conductor is not included shall either be tested as indicated in Clause 5.23 (1 h or longer immersion) or be spark tested as indicated in Clause 5.22, with each layer in a multiple-layer assembly sparked separately.
- c) Each 2.08 – 8.37 mm<sup>2</sup> (14 AWG – 8 AWG) conductor in an assembly shall be individually tested for continuity after the assembly is completed.

## 5 Test requirements

### 5.1 General

Every length of finished insulated conductor shall be capable of meeting the test requirements set out in Clauses 5.2 – 5.25, as applicable.

## 5.2 Conductor resistance

The direct-current resistance of the conductor shall not be greater than shown in Tables 14 – 22 inclusive, except that a tolerance of plus 2 percent shall be optional in the case of conductors twisted together in a multi-conductor assembly. Compliance shall be determined in accordance with the test, DC resistance, in UL 2556, CSA C22.2 No. 2556, or NMX-J-212-ANCE.

## 5.3 Tests on aluminum conductors

### 5.3.1 Physical properties

All aluminum conductors shall have a minimum elongation at break of 10 percent. Wires (strands) removed from a finished stranded conductor shall have a tensile strength of 98 – 159 MPa (14,250 – 23,100 lbf/in<sup>2</sup>). The tensile strength of all other conductors shall be 103 – 152 MPa (15,000 – 22,000 lbf/in<sup>2</sup>). Compliance shall be determined in accordance with the test, Physical properties of conductors – Maximum tensile strength and elongation at break, in UL 2556, CSA C22.2 No. 2556, or NMX-J-556-ANCE.

Compliance with the foregoing requirements for stranded conductors shall be determined either on wires taken prior to stranding into conductors, strands taken from a stranded conductor, or the stranded conductor as a whole, at the option of the manufacturer.

### 5.3.2 High-current heat cycling

5.3.2.1 A minimum of 24 thermocouples (26 thermocouples if one test jig is rejected before 51 cycles are completed) shall measure less than 175°C, with each temperature profile exhibiting thermal stability.

5.3.2.2 Compliance shall be determined in accordance with the test, High-current heat cycling for aluminum conductors, in UL 2556, CSA C22.2 No. 2556, or NMX-J-556-ANCE.

## 5.4 Short-term insulation resistance at elevated temperature in water

The resistance values shall not be less than those shown in Table 23 when tested in accordance with the test, Insulation resistance, in UL 2556, CSA C22.2 No. 2556, or NMX-J-556-ANCE, after immersion in water for at least 6 h at the same temperature as the temperature rating of the insulation.

## 5.5 Long-term insulation resistance in water

### 5.5.1 Minimum acceptable value

5.5.1.1 The insulation of wet-rated single-conductor cable and of the individual single conductors of multiconductor cable shall have insulation resistance at the specified temperature in tap water not less than specified in Table 23 at any time during immersion, in accordance with the test, Insulation resistance, in UL 2556, CSA C22.2 No. 2556, or NMX-J-556-ANCE. The period of immersion shall be 12 weeks or more if the insulation resistance during the last 6 weeks of the period is higher than  $3 \text{ G}\Omega\cdot\text{m}$  ( $10 \text{ M}\Omega\cdot 1000 \text{ ft}$ ). The period of immersion shall be 24 – 36 weeks if the insulation resistance is less than  $3 \text{ G}\Omega\cdot\text{m}$  ( $10 \text{ M}\Omega\cdot 1000 \text{ ft}$ ), but equals or exceeds the value indicated in Table 23. An a-c voltage of 600 V rms shall be applied to the insulation at all times other than while reading the insulation resistance.

In the case of nylon-covered wires, the nylon shall be removed prior to testing.

5.5.1.2 The extended immersion tests at  $50^\circ\text{C}$  ( $122^\circ\text{F}$ ) or  $60^\circ\text{C}$  ( $140^\circ\text{F}$ ) for Types TW and TWU; at  $75^\circ\text{C}$  ( $167^\circ\text{F}$ ) for Types THW, THWN, THW-LS, THHW-LS, THHW, TW75, TWN75, and TWU75; and at  $90^\circ\text{C}$  ( $194^\circ\text{F}$ ) for Types THW-2 and THWN-2 shall be considered accelerated tests.

### 5.5.2 Maximum acceptable rate of decrease

5.5.2.1 During the extended immersion, the maximum decrease in insulation resistance per week, as determined from a curve (drawn to represent the average of actual values), for every continuous period of 3 weeks during the latter half of the specified immersion time shall be not more than 4 percent if and while the insulation resistance is  $3 \text{ G}\Omega\cdot\text{m}$  ( $10 \text{ M}\Omega\cdot 1000 \text{ ft}$ ) or more, and shall be not more than 2 percent if the insulation resistance is less than  $3 \text{ G}\Omega\cdot\text{m}$  ( $10 \text{ M}\Omega\cdot 1000 \text{ ft}$ ), but more than the value indicated in Table 23.

5.5.2.2 Any coil that shows a greater percent decrease in insulation resistance than those indicated in Clause 5.5.2.1 during the extended period of time in the water tank shall be allowed to be tested for additional one week periods in the water tank and judged on the basis of the results for the last 6-week period in the water tank, provided that the final insulation resistance is not less than as specified in Table 23.

## 5.6 Long-term insulation resistance in air for $90^\circ\text{C}$ rated conductors

### 5.6.1 Applicability

This test shall not be required on insulated conductors that meet the requirements of Clause 5.5.

## 5.6.2 Maximum acceptable rate of decrease

5.6.2.1 The maximum acceptable rate of decrease shall be as specified in Clause 5.5.2.

5.6.2.2 Any coil that shows a greater percent decrease in insulation resistance than those indicated in Clause 5.5.2.1 during the extended period of time in the oven shall be allowed to be tested for additional one-week periods in the oven and judged on the basis of the results for every continuous period of 3 weeks during the last 12 weeks in the oven, provided that the final insulation resistance is not less than as specified in Table 23.

## 5.6.3 Minimum acceptable value

5.6.3.1 The 90°C rated insulation of the individual conductors without covering shall have insulation resistance in air at  $97 \pm 1^\circ\text{C}$  that is not less than indicated in Table 24 at any time during an extended period in an acceptable full-draft circulating-air oven under the following conditions. The period in the oven shall be 12 weeks or more, to a maximum of 36 weeks, if the insulation resistance throughout the last 6 weeks of the period is  $3 \text{ G}\Omega\cdot\text{m}$  ( $10 \text{ M}\Omega\cdot 1000 \text{ ft}$ ) or higher. If the insulation resistance is less than  $3 \text{ G}\Omega\cdot\text{m}$  ( $10 \text{ M}\Omega\cdot 1000 \text{ ft}$ ), but equals or exceeds the values in Table 24, the period in the oven shall be 24 weeks or more to a maximum of 36 weeks. A 600 V rms voltage shall be applied at all times other than while reading the insulation resistance.

5.6.3.2 The insulation resistance shall be measured between the conductor and an electrode (either graphite powder or a snug-fitting close-weave copper braid) applied over the insulation, or other equivalent means.

## 5.7 Capacitance and relative permittivity of wet rated ("W" type) wires

Specimens of finished wire immersed in water at rated temperature, 60°C, 75°C, and 90°C, shall comply with each of the following, in accordance with the test, Capacitance and relative permittivity, in UL 2556, CSA C22.2 No. 2556, or NMX-J-040-ANCE:

- a) The relative permittivity determined after immersion for 24 h shall not be more than 10.
- b) The capacitance determined for all insulations after immersion for 14 d shall not be more than 10 percent higher than the capacitance after 24 h immersion.
- c) The capacitance determined for all insulations after the 14 d immersion shall not be more than 5 percent higher than the capacitance determined after immersion for 7 d.

In the case of nylon-covered wires, the nylon shall be removed prior to testing.

## 5.8 Flexibility at room temperature after aging

The insulation and nylon covering (if present) shall not show any cracks, either on the surface or internally, when wound around a mandrel of the diameter specified in Table 25, Column B, at room temperature, in accordance with the test, Flexibility at room temperature after aging, in UL 2556, CSA C22.2 No. 2556, or NMX-J-189-ANCE, after aging in an air oven as specified in Table 11.

## 5.9 Heat shock

5.9.1 When tested in accordance with the test, Heat shock, in UL 2556, CSA C22.2 No. 2556, or NMX-J-190-ANCE, the insulation of single insulated conductors shall not show any cracks, on the surface or internally, after a specimen of finished wire is wound around a mandrel with a diameter specified in Column A of Table 25 after conditioning in an air-circulating oven for 1 h to a temperature of  $121 \pm 1^\circ\text{C}$ .

5.9.2 For  $42.4 \text{ mm}^2$  (1 AWG) and smaller, the specimen shall be tightly wound for four adjacent turns around the mandrel, and both ends of the specimen shall be securely held in place. For  $53.5 \text{ mm}^2$  (1/0 AWG) and larger, a U-bend shall be made between the specimen in contact with the mandrel for not less than  $180^\circ$ .

## 5.10 Cold bend and cold impact

### 5.10.1 Cold bend

5.10.1.1 After conditioning at a temperature of  $-25 \pm 1^\circ\text{C}$  for 4 h, the insulation and nylon covering (if present) shall not show any cracks when tested in accordance with the test, Cold bend, in UL 2556, CSA C22.2 No. 2556, or NMX-J-193-ANCE, modified as indicated in Clause 5.10.1.2. The mandrel diameter shall be as specified in Column B of Table 25. Conditioning at a temperature of  $-40 \pm 1^\circ\text{C}$  shall be optional.

5.10.1.2 In the case of  $85.0 \text{ mm}^2$  (3/0 AWG) or smaller conductors, the specimen shall be tightly wound for four adjacent turns around the mandrel, and the winding shall be done at a uniform rate of approximately 4 s per turn. For sizes  $107 \text{ mm}^2$  (4/0 AWG) and larger, a  $180^\circ$  U-bend shall be performed.

5.10.1.3 When the wire or cable is marked with the optional  $-40\text{C}$  marking in accordance with Clause 6.1.8, conditioning shall be carried out at a temperature of  $-40 \pm 1^\circ\text{C}$ .

### 5.10.2 Cold impact (optional)

The insulation and jacket, where present, on at least 8 out of 10 complete cable specimens shall not crack or rupture when tested at  $-40^{\circ}\text{C}$  in accordance with the test, Cold impact, in UL 2556, CSA C22.2 No. 2556, or NMX-J-556-ANCE.

## 5.11 Deformation

5.11.1 The thickness of  $60^{\circ}\text{C}$ ,  $75^{\circ}\text{C}$ , and  $90^{\circ}\text{C}$  rated insulations shall not decrease by more than 50, 30, and 30 percent, respectively, when subjected to the load specified in Table 26 and tested in accordance with the test, Deformation, in UL 2556, CSA C22.2 No. 2556, or NMX-J-191-ANCE.

5.11.2 Nylon-jacketed conductors shall be maintained at  $136 \pm 1^{\circ}\text{C}$  during the test, with the nylon left in place. Measurements shall be made over the nylon. Except as shown in Clause 5.11.3, all other conductors shall be maintained at  $121 \pm 1^{\circ}\text{C}$  during the test.

5.11.3 In Mexico, Types THHW and THHW-LS conductors shall be maintained at  $136 \pm 1^{\circ}\text{C}$  during the test.

## 5.12 Flame and smoke

### 5.12.1 Vertical flame

When tested in accordance with Clause 8.2.1, a specimen of a wire or cable shall not flame longer than 60 s following five 15 s applications of the test flame, the period between applications being 15 s. If any specimen shows more than 25 percent of the indicator flag burned away or charred (soot that can be removed with a cloth or the fingers and brown scorching area shall be ignored) after any of the five applications of flame, the wire or cable shall be judged capable of conveying flame along its length. If any specimen emits flaming or glowing particles or flaming drops at any time that ignite the cotton on the burner, wedge, or floor of the enclosure (flameless charring of the cotton shall be ignored), the wire or cable shall be judged capable of conveying flame to combustible materials in its vicinity.

### 5.12.2 FT1

In Canada, when tested in accordance with Clause 8.2.2, a finished conductor shall not convey flame or continue to burn for more than 60 s after five 15 s applications of the test flame. If more than 25 percent of the extended portion of the indicator is burned, the conductor shall be considered to have conveyed flame.

In the United States and Mexico, compliance with this requirement shall be optional.

### 5.12.3 VW-1 (optional)

#### 5.12.3.1 Vertical specimen

For a given size of a finished wire or cable to be marked VW-1, that size and 2.08 mm<sup>2</sup> (14 AWG) copper or 3.31 mm<sup>2</sup> (12 AWG) aluminum shall comply with the requirements of the horizontal flame test described in Clause 5.12.3.2, and shall be judged not capable of conveying flame along its length or in its vicinity when tested in accordance with Clause 8.2.3.1. If any specimen shows more than 25 percent of the indicator flag burned away or charred (soot that can be removed with a cloth or the fingers and brown scorching area shall be ignored) after any of the five applications of flame, the wire or cable shall be judged capable of conveying flame along its length. If any specimen emits flaming or glowing particles or flaming drops at any time that ignite the cotton on the burner, wedge, or floor of the enclosure (flameless charring of the cotton shall be ignored), the wire or cable shall be judged capable of conveying flame to combustible materials in its vicinity. If any specimen continues to flame longer than 60 s after any application of the gas flame, the wire or cable shall be judged capable of conveying flame to combustible materials in its vicinity.

#### 5.12.3.2 Horizontal specimen

Each size of a given construction of a finished wire that is marked VW-1, in addition to complying with Clause 5.12.3.1, shall be capable of not conveying flame along its length or in its vicinity when a specimen is subjected to the flame test described in Clause 8.2.3.2. The total length of the char in the specimen shall not exceed 100 mm (4 inches), and the dripping particles emitted by the specimen during or after the application of the flame shall not ignite the cotton on the floor of the enclosure, on the base of the burner, or on the wedge.

#### 5.12.4 Vertical tray (optional)

Finished single conductors shall not exhibit damage that reaches the upper end of any of two sets of specimen, when subjected for the specified period to the flame test in Clause 8.2.4.

#### 5.12.5 FT4 vertical tray (optional)

Finished single conductors shall not exhibit charred material beyond a length exceeding 1.5 m from the flame impingement, when tested for the specified period in accordance with Clause 8.2.5.

## 5.12.6 ST1 limited-smoke (optional)

### 5.12.6.1 General

When tested in accordance with Clause 8.2.6, each finished insulated single conductor shall meet the test criteria in Clauses 5.12.4 or 5.12.5. Limits are specified for each fire test to make the following tests equally acceptable for the purpose of quantifying the smoke. The cable manufacturer shall specify, for testing each ST1 (limited-smoke) cable construction, either the vertical flame exposure described in Clause 8.2.6.1 or the vertical flame exposure described in Clause 8.2.6.2.

Typically, for a range of sizes to be marked ST1, the smallest conductor in the range, the smallest conductor employing the same insulation thickness as the largest conductor in the range, and an intermediate conductor shall be selected for testing. Testing of individual conductor sizes shall be optional.

### 5.12.6.2 Vertical-tray flame exposure

Finished insulated single conductors shall exhibit the following properties when tested in accordance with Clause 8.2.6.1:

- a) The cable damage height for each set of specimens shall be less than 2.44 m (8 ft) when measured from the bottom of the cable tray.
- b) The total smoke released in 20 min for each set of specimens shall not exceed 95 m<sup>2</sup>.
- c) The peak smoke release rate for each set of specimens shall not exceed 0.25 m<sup>2</sup>/s.
- d) The values of cable damage height, total smoke released, and peak smoke release rate obtained from one set of specimens shall not differ by more than 15 percent from the values obtained from the second set of specimens. If any of the values differ by more than 15 percent between the two sets of specimens, a third set of specimens shall be tested as described in Clause 8.2.6.1. The values obtained from the third set of specimens shall be within the limits specified in a), b), and c).

### 5.12.6.3 FT4 vertical-tray flame exposure

Finished insulated single conductors shall exhibit the following properties when sets of specimen lengths are tested in accordance with Clause 8.2.6.2:

- a) The cable damage height for each set of specimens shall be less than 1.50 m when measured from the bottom of the cable tray.
- b) The total smoke released in 20 min for each set of specimens shall not exceed 150 m<sup>2</sup>.
- c) The peak smoke release rate for each set of specimens shall not exceed 0.40 m<sup>2</sup>/s.
- d) The values of cable damage height, total smoke released, and peak smoke release rate obtained from one set of specimens shall not differ by more than 15 percent from the values obtained from the second set of specimens. If any of the values differ by more than 15 percent between the two sets of specimens, a third set of specimens shall be tested as described in Clause 8.2.6.2. The values obtained from the third set of specimens shall be within the limits specified in a), b), and c).



## 5.12.7 LS (low-smoke): flame, smoke, and acid-gas release

### 5.12.7.1 General

The requirements of 5.12.7.2 – 5.12.7.4 apply to Types THW-LS and THHW-LS and shall be mandatory for all other types marked "LS".

### 5.12.7.2 Smoke emission

The components of cables shall be tested in accordance with the method described in Clause 8.2.7.1 to obtain the smoke-emission performance. For cables up to 10 mm (0.40 inch) external diameter, the maximum specific optical density (DM) shall not be more than 500, and the value of smoke obscuration in the first four minutes (VOF<sub>4</sub>) shall not be more than 400. For cables with an external diameter larger than 10 mm (0.40 inch), the maximum specific optical density (DM) shall not be more than 500, and the value of smoke obscuration in the first four minutes (VOF<sub>4</sub>) shall not be more than 800. Tests shall be performed on die-cut specimens 2 mm (0.08 inch) in thickness.

### 5.12.7.3 Fire propagation (RPI)

Finished cable samples shall be subjected to the test method described in Clause 8.2.7.2 for testing fire-propagation resistance of single or multiple conductors. The cables shall be considered in compliance if the damage produced by the test does not exceed the upper limit of the chimney of the testing equipment (0.80 m over the oven).

### 5.12.7.4 Halogen acid gas emission

Samples of nonmetallic materials of cables when tested in accordance with the method described in Clause 8.2.7.3 shall have a maximum loss of mass, in the form of acid-gas emission produced by pyrolysis, not greater than 20 percent. Acid gas shall be expressed as percentage of the hydrogen chloride evolved during the test.

## 5.13 Weather resistance (optional)

To be marked SR, the insulation of a single wet-rated conductor having no outer jacket or covering, the outer jacket of a multiconductor cable, and the insulation and nylon covering of nylon-covered conductors of a completed single wire or a multiconductor cable shall retain at least 80 percent of their unconditioned tensile strength and elongation values, after conditioning by exposure to xenon- or carbon-arc.

In the United States and Mexico, the conditioning shall be 720 h.

In Canada, the conditioning shall be 1000 h.

Compliance shall be determined in accordance with the applicable clauses of the test, Physical Properties – Weather (sunlight) resistance, in UL 2556, CSA C22.2 No. 2556, or NMX-J-553-ANCE.

## **5.14 Oil resistance (optional)**

### **5.14.1 Oil resistance at 60°C**

5.14.1.1 To be marked PR I, the retention of tensile strength and elongation of the insulation shall not be less than 50 percent of the unconditioned value after immersion of the finished wire in IRM 902 oil for 96 h at 100°C. Compliance shall be determined in accordance with the applicable clauses of the test, Oil resistance, in UL 2556, CSA C22.2 No. 2556, or NMX-J-194-ANCE.

5.14.1.2 Specimens of wire shall be immersed without removal of the nylon jacket, if present. After immersion for the specified length of time, each specimen shall be cut in half at the center of the U bend to provide two specimens for physical tests from each length immersed. The nylon covering shall be removed prior to the physical tests.

### **5.14.2 Oil resistance at 75°C**

5.14.2.1 To be marked PR II, the retention of tensile strength and elongation of the insulation shall be not less than 65 percent of the unconditioned value after immersion of the finished wire in IRM 902 oil for 60 d at 75°C. Compliance shall be determined in accordance with the applicable clauses of the test, Oil resistance, in UL 2556, CSA C22.2 No. 2556, or NMX-J-556-ANCE.

5.14.2.2 Specimens of wire shall be immersed without removal of the nylon jacket, if present. After immersion for the specified length of time, each specimen shall be cut in half at the center of the U bend to provide two specimens for physical tests from each length immersed. The nylon covering shall be removed prior to the physical tests.

## **5.15 Gasoline and oil resistance (optional)**

5.15.1 To be marked GR I or GR II, the retention of tensile strength and elongation of insulated conductors found to be in compliance with the requirements of Clause 5.14.1 or 5.14.2, respectively, shall not be less than 65 percent after 30 d immersion in water saturated with equal volumes of iso-octane and toluene (ASTM Reference Fuel C) maintained at  $23 \pm 1^\circ\text{C}$ . Compliance shall be determined in accordance with the applicable clauses of the test, Gasoline resistance, in UL 2556, CSA C22.2 No. 2556, or NMX-J-556-ANCE.

5.15.2 Specimens of wet rated wire shall be immersed without removal of the nylon jacket, if present. After immersion for the specified length of time, each specimen shall be cut in half at the center of the U bend to provide two specimens for physical tests from each length immersed. The nylon covering shall be removed prior to the physical tests.

### **5.16 Abrasion resistance (nylon-covered types or insulations other than PVC)**

The insulation and nylon jacket (if present) on solid 2.08 mm<sup>2</sup> (14 AWG) conductors shall not wear through to expose the conductor on any of 6 specimens subjected to 800 cycles of abrasion by means of a weight that exerts a force of 3.3 ±0.1 N or 340 ±13 gf (12.0 ±0.5 ozf), in accordance with the procedure described in the test, Abrasion resistance, in UL 2556, CSA C22.2 No. 2556, or NMX-J-556-ANCE.

In Mexico, the abrasion resistance test is not required.

### **5.17 Crush resistance (nylon-covered types or insulations other than PVC)**

An average of not less than 1000 N (225 lbf) shall be necessary to crush solid 2.08 mm<sup>2</sup> (14 AWG) insulated conductors until contact is established between the earth-grounded flat steel plate or steel rod when 10 specimens of the finished wire are subjected to the crushing procedure described in the test, Crush resistance – Method 2, in UL 2556, CSA C22.2 No. 2556, or NMX-J-556-ANCE.

### **5.18 Impact resistance (nylon-covered types or insulations other than PVC)**

A free-falling steel weight that impacts with an energy of 2.7 J (2 ft-lbs) upon the insulation and nylon jacket (if present) of a solid 2.08 mm<sup>2</sup> (14 AWG) specimen shall not expose the conductor or cause triggering of the indicator when tested in accordance with the test, Impact resistance, in UL 2556, CSA C22.2 No. 2556, or NMX-J-556-ANCE.

### **5.19 Durability of ink printing**

5.19.1 The printing on the finished wire shall remain legible after being subjected to the test, Durability of ink printing, in UL 2556, CSA C22.2 No. 2556, or NMX-J-556-ANCE.

5.19.2 One of two specimens shall be conditioned in a forced air oven at the rated temperature of the specimen for 24 h; the other left at room temperature for 24 h.

### **5.20 Color coating**

5.20.1 Surface (ink or paint) coated thermoplastic-insulated wire shall comply with the requirements in Clauses 5.20.2 – 5.20.4, when tested in accordance with the test, Color coating, in UL 2556, CSA C22.2 No. 2556, or NMX-J-556-ANCE.

5.20.2 The surface-coated thermoplastic-insulated conductor shall comply with the tensile strength and ultimate elongation requirements before and after the air-oven aging applicable to the insulation.

5.20.3 The coating shall not flake off of the surface of the insulation when samples of the wire are flexed at room temperature in the manner described in the test, Color coating, in UL 2556, CSA C22.2 No. 2556, or NMX-J-556-ANCE both before and after the air-oven aging applicable to the insulation.

5.20.4 The surface coating shall not migrate when tested in accordance with the test, Color coating, in UL 2556, CSA C22.2 No. 2556, or NMX-J-556-ANCE.

## 5.21 Long-term aging of insulation

5.21.1 The absolute elongation of insulation material referenced in Clause 4.2.5.3 shall be not less than 50 percent after being subjected to long-term aging in an air oven in accordance with the test, Dry temperature rating of new materials (long-term aging test), in UL 2556, CSA C22.2 No. 2556, or NMX-J-186-ANCE.

5.21.2 The minimum unaged and aged tensile and ultimate elongation values for the compound shall be established at 85 percent of the average measured value of the six specimens.

5.21.3 The applicable test duration and temperature shall be in accordance with Table 12.

## 5.22 A-C spark test

5.22.1 Every finished production length of single-conductor cable shall be subjected either:

a) To the a-c spark test in accordance with the test, Spark, in UL 2556, CSA C22.2 No. 2556, or NMX-J-473-ANCE. The test potential shall be as shown in Table 40; or

In Mexico, the a-c spark test is not required.

b) To the dielectric voltage-withstand in water test described in Clause 5.23, and the insulation resistance in water test at 15°C described in Clause 5.24.

In the event that option a) is chosen, the finished wire or cable shall be capable of complying with the tests referenced in option b).

## 5.23 Dielectric voltage-withstand in water

5.23.1 The insulation of single conductors, when tested in accordance with the test, Dielectric voltage-withstand, in UL 2556, CSA C22.2 No. 2556, or NMX-J-293-ANCE shall withstand, without breakdown, the application of the appropriate test voltage after immersion in water for not less than 6 h before the test potential is applied, as follows:

a) The ac test voltage specified in Table 41 for 1 minute;

b) Alternatively, a dc test voltage of 3 times the ac test voltage specified in Table 41 for the same period.

In Mexico, the dc test is not required.

## 5.24 Insulation resistance in water at 15°C

Following compliance with Clause 5.23, while still immersed, the insulation of single conductors shall have an insulation resistance, corrected to 15°C, if necessary, of not less than the values specified in Table 27 when tested at the prevailing water temperature. The apparatus and test method shall be in accordance with the test, Insulation resistance, in UL 2556, CSA C22.2 No. 2556, or NMX-J-294-ANCE. Unless the spark test specified in Clause 5.22 is carried out, each length of finished cable shall be subjected to this test.

## 5.25 Electrical continuity

Each conductor shall be continuous when tested in accordance with either Method 1 or Method 2 described in the test, Continuity, in UL 2556, CSA C22.2 No. 2556, or NMX-J-556-ANCE.

## 6 Marking

*Advisory Note: In Canada, there are two official languages, English and French, and in Mexico, the official language is Spanish. Annex H provides translations in French and Spanish of the English markings specified in this Standard. Markings required by this Standard may have to be provided in other languages to conform with the language requirements of the country where the product is to be used.*

### 6.1 Marking on product

#### 6.1.1 General

All markings on the finished product shall be visible and legible. The use of surface printing, indent, or embossed marking shall meet the intent of this requirement. The process shall not result in a thickness less than the minimum specified.

The marking legend shall be repeated at intervals not exceeding 1.0 m (40 inches), except for conductor size, which shall be repeated at intervals not exceeding 610 mm (24 inches).

Clauses 6.1.2 – 6.1.7 describe required markings. Clauses 6.1.8 – 6.1.12 describe optional markings.

Marking on a product shall be optional when the product is intended for use in a product covered by another end-product standard (further processing).

### 6.1.2 Manufacturer's identification

A finished wire or cable shall have a durable distinctive marking throughout its entire length by which the organization responsible for the product is readily identified.

### 6.1.3 Type designation

6.1.3.1 The type designation, as described in Table 1, shall be marked as indicated in Clause 6.1.1. The use of the word "Type" shall be optional. Marking of the maximum operating dry and wet temperature rating of insulation as applicable shall be optional.

6.1.3.2 A wire or cable that complies with all the requirements of two or more types shall be allowed to be marked to so indicate – e.g., THHN T90 NYLON or THHN/THWN.

### 6.1.4 Conductor size

The size of conductors shall be marked on the product, expressed in one or more of the following forms:

- a) mm<sup>2</sup> (AWG);
- b) AWG (mm<sup>2</sup>);
- c) mm<sup>2</sup> (kcmil);
- d) kcmil (mm<sup>2</sup>);
- e) AWG;
- f) kcmil.

In Mexico, items a) and c) apply.

In Canada, items a), b), c), and d) apply.

In the United States, items a), b), c), d), e), and f) apply.

The use of either a comma or a period signifies a decimal. For printing on products, the use of mm<sup>2</sup> in place of mm<sup>2</sup> shall be allowed.

### 6.1.5 Aluminum conductors

Aluminum conductors shall be marked "AL". The additional marking "ACM" shall be optional.

### 6.1.6 Compact copper conductors

In the United States, the following applies: compact-stranded copper conductors shall be marked "Compact Copper", or "Compact Cu", or "Cmpct Cu" after the conductor size.

In Canada and Mexico, this requirement does not apply.

### 6.1.7 Voltage marking

A wire or cable shall be marked with its voltage rating, using "V", "volts", or "VOLTS".

### 6.1.8 Low-temperature marking (optional)

A wire or cable marked "(-40°)" shall meet the requirements for -40°C cold bend and cold impact specified in Clause 5.10.

### 6.1.9 Flame test marking (optional)

#### 6.1.9.1 General

Insulated conductors with the following markings shall meet the requirements of the corresponding clauses:

- a) "FT1": Clause 5.12.2;
- b) "VW-1": Clause 5.12.3;
- c) "CT": Clause 5.12.4 or 5.12.5 (see 6.1.9.2 for applicability);
- d) "FT4": Clause 5.12.5 or 5.12.6 using flame exposure in accordance with Clause 8.2.6.2;
- e) "ST1": Clause 5.12.6;
- f) "LS": Clause 5.12.7;
- g) "RPI": Clause 5.12.7.3.

### 6.1.9.2 Cable-tray use marking (optional)

6.1.9.2.1 Insulated conductors marked "CT" shall meet the requirements of either Clause 5.12.4 or Clause 5.12.5.

6.1.9.2.2 In the United States, this marking shall be allowed on single circuit conductors of size 53.5 mm<sup>2</sup> (1/0 AWG) and larger, and equipment-grounding conductors of size 21.2 mm<sup>2</sup> (4 AWG) and larger.

6.1.9.2.3 In Mexico, the marking "CT" shall be allowed on single circuit conductors 21.2 mm<sup>2</sup> (4 AWG) and larger.

6.1.9.2.4 In Canada, the marking "CT" is not recognized by the *Canadian Electrical Code, Part I*.

### 6.1.10 Weather resistance (optional)

Wires or cables marked "SR" shall meet the requirements of Clause 5.13. When marked "SR", the additional markings "Sunlight Resistant" or "Sun Res" shall be allowed.

### 6.1.11 Oil resistance (optional)

Wires or cables marked "PR I" shall meet the requirements of Clause 5.14.1. Wires or cables marked "PR II" shall meet the requirements of Clause 5.14.2.

### 6.1.12 Gasoline and oil resistance (optional)

Wires or cables marked "GR I" shall meet the requirements of Clauses 5.14.1 and 5.15. Wires or cables marked "GR II" shall meet the requirements of Clauses 5.14.2 and 5.15.

## 6.2 Marking on package

Each package of wire or cable shall be tagged or marked to indicate legibly the following:

- a) Manufacturer's identification;
- b) Type designation;
- c) Conductor size, in accordance with Clause 6.1.4;
- d) "AL" after the conductor size (item c), when aluminum conductor is used. The additional marking "ACM" shall be optional;
- e) If compact stranding is used, the word "COMPACT" or "CMPCT";
- f) In the United States, if stranded copper conductors are compacted, the words "Compact Copper" or "Compact Cu" or "Cmpct Cu" shall be included adjacent to the conductor size (item c). The following statement shall also appear on the package: "Terminate with connectors identified for use with compact-stranded copper conductors";

In Canada and Mexico, this requirement does not apply.

- g) Voltage rating;
- h) Maximum operating dry and wet temperature ratings of insulation shall be optional.



### 6.3 Month and year of manufacture

The month and year of manufacture shall be included among the package markings described in Clause 6.2 or shall be included among the product markings described in Clause 6.1. The use of a code shall be allowed.

## 7 Deep-well submersible water pump cable

### 7.1 General

The construction of deep-well submersible water pump cable shall consist of assemblies comprising two or more insulated circuit conductors having a wet rating, and an optional insulated equipment grounding conductor, with or without an overall jacket. These cables shall be of the twisted or parallel configuration with the option of having a low temperature rating of  $-40^{\circ}\text{C}$ .

### 7.2 Construction

#### 7.2.1 Conductors

Circuit conductors shall consist of solid or stranded  $2.08 - 33.6 \text{ mm}^2$  (14 – 2 AWG) copper, solid or stranded  $3.31 - 33.6 \text{ mm}^2$  (12 – 2 AWG) aluminum ACM, or stranded  $42.4 - 253 \text{ mm}^2$  (1 AWG – 500 kcmil) copper or aluminum ACM. The optional insulated equipment-grounding conductor shall be of the same construction as the circuit conductor, and of a size that is not smaller than indicated in Table 28, except that a copper equipment-grounding conductor shall be allowed with aluminum circuit conductors, as described in Table 28. An aluminum equipment-grounding conductor shall be allowed with copper circuit conductors, as described in Table 29. All of the conductors shall comply with Clause 4.1.

#### 7.2.2 Insulation

Insulated conductors of the types listed in Groups I, II, and III of Table 30, assemblies a), b), and d) of Clause 7.2.3, shall comply with the requirements of Clauses 1 – 6 of this Standard. Insulated conductors of the types listed in Groups I and III, assembly c), shall have an integral insulation-jacket consisting of the sum of the thickness of insulation of Table 10 corresponding to the types listed, plus the thickness of integral jacket from Table 31.

The insulation and integral jacket shall be of the same compound as the listed product and shall comply with the applicable requirements of Clauses 1 – 6, and the assembly shall comply with the requirements of Clause 7.4.

Polyethylene-insulated conductors of Group IV, assembly d) of Clause 7.2.3 shall be insulated with unfilled polyethylene and shall comply with Tables 32 and 33 and the applicable test methods of this Standard.

### 7.2.3 Assembly

The conductors shall be assembled in one of the following ways:

- a) **CABLED WITH OVERALL JACKET:** this cable assembly has two or more insulated circuit conductors from Group I, II, III, or IV of Table 30 and shall be cabled together with an optional insulated equipment-grounding conductor in either a right- or left-hand lay of unspecified length, with an overall jacket. The jacket shall comply with the thickness requirements of Table 34 and the physical properties specified in Table 36.
- b) **CABLED WITHOUT OVERALL JACKET:** this cable assembly has from two to six insulated circuit conductors from Group I of Table 30 with an individual jacket in accordance with Table 31, or from Group III of Table 30, and shall be cabled together helically with an optional insulated equipment-grounding conductor in either a right- or left-hand lay of unspecified length, without an overall jacket.
- c) **PARALLEL WITH INTEGRAL WEB WITHOUT OVERALL JACKET:** this cable assembly has two, three, or four circuit conductors from Group I of Table 30 with an integral jacket from Table 31, or from Group III of Table 30, together with any optional equipment-grounding conductor laid parallel on the same axis. The conductors are joined to one another with an interconnecting web. The conductor insulation, or integral insulation, and jacket shall be extruded simultaneously with the interconnecting web and shall be of the same compound. The minimum thickness of insulation at any point on any conductor, after separation, shall not be less than required for the specified wire type.
- d) **PARALLEL WITH OVERALL JACKET WITH INTEGRAL FILLERS OR WEBS:** this cable assembly has two, three, or four insulated circuit conductors from Group I, II, III, or IV of Table 30 laid parallel on the same axis, together with an optional insulated equipment-grounding conductor and an overall jacket that complies with the thickness requirements of Table 34, and the requirements for physical properties specified in Table 36.

The jacket shall be extruded to form either an interconnecting web of unspecified thickness between the conductors or fillers that are integral with the jacket. The degree to which the integral fillers fill the valleys between the conductors is not specified, except that the fill shall maintain the stability of the flat construction.

#### 7.2.4 Polarity identification of circuit conductors

Polarity identification of circuit conductors other than the grounding or grounded conductor shall be provided by means of contrasting colors other than white, gray, or green; by ridges; by stripes; or by word printing. Grounded circuit conductors shall be colored white or gray, or shall have white stripes. The equipment-grounding conductor shall be colored green or green with yellow stripes.

In the case of a flat cable that includes an insulated equipment-grounding conductor, the grounding conductor shall be identified by means of legible, durable ink printing, that reads "GND" or  $\perp$  on the outer surface of the finished conductor. The additional words "GROUNDING ONLY" shall be allowed.

### 7.3 Marking

*Advisory Note: In Canada, there are two official languages, English and French, and in Mexico, the official language is Spanish. Annex H provides translations in French and Spanish of the English markings specified in this Standard. Markings required by this standard may have to be provided in other languages to conform with the language requirements of the country where the product is to be used.*

#### 7.3.1 Marking on product

Deep-well submersible water pump cable shall be legibly and durably marked to indicate the following:

- a) The manufacturer's identification;
- b) The number of circuit conductors (in the case of jacketed constructions);
- c) The conductor size in accordance with Clause 6.1.4;
- d) The word "AL", if aluminum conductors are used. The additional marking "ACM" shall be optional;
- e) The designation "SUBMERSIBLE PUMP CABLE" as applicable (required on jacketed constructions, optional on conductors of non-jacketed constructions);
- f) The nominal voltage rating, in accordance with Clause 6.1.7;
- g) The low-temperature rating, marked in accordance with Clause 6.1.8, for cables complying with Clause 7.4.4;
- h) The type designation of individual conductors, either on the conductor insulation surface or the outer jacket. In the case of polyethylene-insulated conductors, the marking "PE 75C" shall be applied on the outer jacket;
- i) Optional markings specified in Clause 6.1 as applicable.

The above markings shall be surface ink-printed, indented, or embossed at intervals of not more than 0.6 m. Indent markings shall be such that the minimum specified thickness of the jacket or insulation is maintained.

### 7.3.2 Marking on package

Each packaged coil or reel of cabled or parallel assembly, and of jacketed cables, shall be tagged or marked to indicate legibly the following:

- a) Manufacturer's name;
- b) Month and year of manufacture;
- c) Product designation "SUBMERSIBLE PUMP CABLE";
- d) Conductor size in accordance with Clause 6.1.4;
- e) "AL", if aluminum conductors are used. The additional marking "ACM" shall be optional;
- f) Nominal voltage rating, in accordance with Clause 6.1.7;
- g) Low-temperature rating marking, in accordance with Clause 6.1.8, for cables in compliance with Clause 7.4.4;
- h) In the United States and Canada, the notation "For Wiring Only Between Equipment Located at Water Well Heads and Motors of Installed Deep-Well Submersible Water Pumps".  
  
In Mexico, this marking does not apply;
- i) Type designation of the individual conductors. In the case of polyethylene- insulated cables, the marking "PE 75C" shall be applied on the jacket.

## 7.4 Tests

### 7.4.1 General

In addition to the tests performed on each insulated conductor according to its type as specified in Clause 5, or in the case of polyethylene-insulated conductors as specified in Table 33, and the spark test specified in the Table 32, the completed cable shall be subjected to the tests set out in Clauses 7.4.2 – 7.4.5.

#### 7.4.2 Dielectric withstand

The finished assembly or cable shall withstand the a-c voltage specified in Clause 5.23, or in the case of polyethylene cables, Table 32. For a flat or twisted assembly, the test voltage shall be applied between each conductor and tap water in which the assembly has been immersed for 6 h.

For a jacketed cable, the test voltage shall be applied to each conductor while the remaining conductors are connected together and connected to ground.

#### 7.4.3 Insulation resistance

The finished assembly of polyethylene-insulated conductor with jacket, and the cables of assembly c) in Clause 7.2.3, shall withstand an insulation resistance test applied between each conductor while the remaining conductors are connected together and connected to ground. Polyethylene-insulated conductors shall have an insulation resistance not less than that calculated for a constant K of 15,000 GΩ·m at 15°C.

#### 7.4.4 Low-temperature impact

In Canada, the thermoplastic jacket or insulation on at least 8 out of 10 specimens of completed cable marked “-40°C” shall not crack or rupture when subjected to the tests, Cold bend and Cold impact, in UL 2556, CSA C22.2 No. 2556, or NMX-J-177-ANCE.

In the United States and Mexico, compliance with this requirement shall be optional.

#### 7.4.5 Electrical continuity

Each conductor shall be continuous when tested in accordance with the test, Continuity, in UL 2556, CSA C22.2 No. 2556, or NMX-J-556-ANCE.

### 8 Test methods

#### 8.1 General

The test methods are presented in Clause 8.2.

## 8.2 Flame

### 8.2.1 Vertical flame

8.2.1.1 The standard test flame shall be nominally 125 mm high and shall produce heat at the nominal rate of 500 W (1700 Btu/h). The period between applications shall be 15 s regardless of whether flaming of the specimen ceases of its own accord within 15 s of the previous application. This test shall be conducted as described in UL 1581, Section 1060; CSA C22.2 No. 0.3, Clause 4.11.7; or NMX-J-192-ANCE, except as described in Clause 8.2.1.2. The results of this test shall be judged as indicated in Clause 8.2.1.3.

8.2.1.2 The burner shall be tilted forward into position to apply the gas flame to the specimen, kept there for 15 s, quickly tilted back to the stop to remove the flame from the specimen for 15 s, and so forth, for a total of five 15 s applications of the gas flame to the specimen, with 15 s between applications. The gas flame shall be reapplied to the specimen 15 s after the previous application, regardless of whether flaming of the specimen ceases of its own accord within 15 s of the previous application.

8.2.1.3 Where any specimen shows more than 25 percent of the indicator flag burned away or charred (soot that can be removed with a cloth or the fingers and brown scorching shall be ignored) after any of the five applications of flame, the insulated conductor shall be judged capable of conveying flame along its length.

Where any specimen emits flaming or glowing particles or flaming drops at any time that ignite the cotton on the burner, wedge, or floor of the enclosure (flameless charring of the cotton shall be ignored), the insulated conductor shall be judged capable of conveying flame to combustible materials in its vicinity. Where any specimen continues to flame longer than 60 s after the five applications of the gas flame, the insulated conductor shall be judged capable of conveying flame to combustible materials in its vicinity.

### 8.2.2 FT1

Compliance shall be determined in accordance with UL 1581, Section 1060; CSA C22.2 No. 0.3, Clause 4.11.1; or NMX-J-192-ANCE.

### 8.2.3 VW-1

#### 8.2.3.1 Vertical specimen

Compliance shall be determined in accordance with UL 1581, Section 1080; CSA C22.2 No. 0.3, Clause 4.11.7; or NMX-J-192-ANCE.

### 8.2.3.2 Horizontal specimen

Compliance shall be determined in accordance with UL 1581, Section 1100; CSA C22.2 No. 0.3, Clause 4.11.2; or NMX-J-192-ANCE.

### 8.2.4 Vertical tray

Compliance shall be determined with the apparatus and method specified in Clause 8.2.6.1. Smoke measurements shall not be applicable.

### 8.2.5 FT4 vertical tray

Compliance shall be determined in accordance with UL 1685, Sections 12 – 19; CSA C22.2 No. 0.3, Clause 4.11.4; or NMX-J-498-ANCE. Smoke measurements shall not be applicable.

### 8.2.6 ST1 limited smoke

#### 8.2.6.1 Vertical-tray fire propagation and smoke release

##### 8.2.6.1.1 Apparatus

The test apparatus shall include the following main components:

- a) Ignition source;
- b) Collection hood and exhaust duct;
- c) Velocity-measuring instrumentation;
- d) Smoke-measuring instruments;
- e) Data-acquisition system.

##### 8.2.6.1.2 Cable test enclosure and exhaust duct

The enclosure in which the cables are tested shall be as shown in Figure 1. Other enclosures shall be optional if they are shown to provide equivalent results, and are of a size [such as 2.4 m<sup>3</sup> (8 ft<sup>3</sup>) or 3 m<sup>3</sup> (10 ft<sup>3</sup>)] such that the internal volume of the enclosure, exclusive of the pyramidal hood, is not less than 14.5 m<sup>3</sup> (512 ft<sup>3</sup>) or greater than 36 m<sup>3</sup> (1272 ft<sup>3</sup>), the floor area is not smaller than 6 m<sup>2</sup> (64 ft<sup>2</sup>) or larger than 9 m<sup>2</sup> (97 ft<sup>2</sup>), and the maximum air movement within the enclosure complies with Clause 8.2.6.1.3.

The walls of the structure shall be of concrete masonry having a density of 1698 kg/m<sup>3</sup> (106 lb/ft<sup>3</sup>) and a thermal conductivity  $k$  at 21.1°C (70.0°F) of 0.055 W/(m·K) [0.38 Btu (thermochemical)·in/(hr·ft<sup>2</sup>·°F)], with the interior surface painted flat black. The walls shall contain window(s) as shown in Figure 1 for observation of the fire test. Alternative construction materials shall be acceptable for the structure walls if both of the following conditions are met:

- a) The overall thermal conductivity, based on an inside wall temperature of 37.8°C (100.0°F) and an outside air temperature of 23.9°C (75.0°F), is  $0.072 \pm 0.043$  W/(m·K) [ $0.50 \pm 0.30$  Btu (thermochemical)·in/(hr·ft<sup>2</sup>·°F)].
- b) The construction materials withstand the high temperatures and open flame in the test enclosure.

The enclosure shall contain a steel access door. The door shall be provided with a wired-glass window and shall be located as shown in Figure 1. The door and hood shall have an overall thermal conductivity equal to that of the walls. Alternative construction materials shall be acceptable if equivalent thermal conductivity is obtained.

A truncated-pyramid steel hood and a collection box, each formed as shown in Figure 1, shall be located on top of the enclosure walls. Compressible inorganic batting shall be used as a gasket between the hood and the walls.

The exhaust duct connected to the plenum on the hood shall consist of a steel pipe 406 mm (16 inches) in inside diameter installed horizontally as shown in Figure 1.

The baffle shown in Figure 1 shall be constructed of a 3.2 mm (1/8 inch) thick steel plate suspended horizontally over the center of the tray by chains attached to each corner of the baffle and connected to the collection hood. The baffle shall be suspended 2.95 m (116 inches) above the floor.

#### 8.2.6.1.3 Velocity-measuring instruments

The velocity in the exhaust duct shall be determined by measuring the differential pressure in the flow path with the bi-directional probe shown in Figure 2. The probe shall be connected to an electronic pressure gauge or to an equivalent measuring system. The probe shall be 44 mm (1.75 inches) long and shall have an outside diameter of 22 mm (0.875 inch). The pressure taps (tubes) on either side of the diaphragm shall support the probe.

The axis of the probe shall be located on the centerline of the duct a minimum of 4 m (13 ft, 4 inches) downstream from the last turn in the duct, to ensure a nearly uniform velocity of flow across the duct cross-section. Positioning of the probe at another location shall be acceptable if it is shown that equivalent results are obtained. The pressure taps shall be connected to a pressure transducer having a minimum resolution of 0.025 Pa (0.001 lb/in<sup>2</sup>).

The temperature of the exhaust gas shall be measured approximately 152 mm (6 inches) upstream from the probe on the centerline of the duct, using a 0.08 mm<sup>2</sup> (28 AWG) Type K thermocouple having an inconel sheath.

The maximum air movement within the enclosure, with only the intake and exhaust openings open, the exhaust fan on (if applicable), and the burner off, shall not exceed 1 m/s (3.3 ft/s), as measured in each of the following areas by means of a vane anemometer:

- a) On the floor of the enclosure at the position occupied by the burner during the test;
- b) 1.5 m (4.9 ft) above the floor of the enclosure at the position occupied by the cable tray during the test.



#### 8.2.6.1.4 Cable tray

A steel ladder type of cable tray that is clean and free of residue and debris shall be securely mounted in a vertical position. The tray shall be 300 mm (12 inches) wide by 76 mm (3 inches) deep by 2400 mm (96 inches) long and shall have channel rungs as follows:

- a) Each rung shall measure approximately 25 mm (1 inch) in the direction parallel to the length of the tray and approximately 13 mm (1/2 inch) in the direction of the depth of the tray.
- b) The rungs shall be spaced approximately 230 mm (9 inches) apart (measured center to center).
- c) The rungs shall be tack-welded to the side rails.

#### 8.2.6.1.5 Burner

The test flame shall be supplied by means of a strip or ribbon type of propane-gas burner.\* The flame-producing surface (face) of the burner shall consist essentially of a flat metal plate that is 341 mm (13-7/16 inches) long and 30 mm (1-5/32 inches) wide. The plate shall have an array of 242 holes drilled in it. The holes shall be 1.35 mm (1.35 mm metric drill size) [0.052 inch (No. 55 drill)] in diameter and shall be on 3.2 mm (0.125 inch) centers in three staggered rows of 81, 80, and 81 holes each, to form an array measuring 257 mm (10-1/8 inches) by 5 mm (3/16 inch). The array of holes shall be centered on the plate (see Figure 3).

\* A burner (catalog no. 10L 11-55) and venturi mixer (catalog no. 14-18) that facilitate compliance with the requirements in Clauses 8.2.6.1.5 and 8.2.6.2.5 are available from the AGF Burner Inc., 1955 Swarthmore Ave., Lakewood, NJ 08701, USA.

The burner shall be mounted on a stand behind the vertical tray containing the cables, with the flame-producing surface (face) of the burner vertical and its long dimension horizontal. The 257 mm (10-1/8 inches) dimension of the array of holes shall be spaced 76 mm (3 inches) from the cables in the tray and shall be centered midway between the side rails of the tray. The centerpoint of the burner face shall be positioned 457 mm (18 inches) above the bottom end of the tray and cables and midway between two tray rungs.

#### 8.2.6.1.6 Flowmeters

A flowmeter shall be inserted in each of the propane and air lines feeding the burner, to measure the flow rates of these gases during the test.

The propane flowmeter shall be capable of measuring a flow rate of  $2.3 \times 10^{-4} \text{ m}^3/\text{s}$  (29 ft<sup>3</sup>/hr), and the air flowmeter  $13.3 \times 10^{-4} \text{ m}^3/\text{s}$  (170 ft<sup>3</sup>/hr). Measurements shall be accurate within 3 percent. The use of a mass-flow controller with recorded output shall be optional.

#### 8.2.6.1.7 Air

The air supplied to the burner shall be compressed air, either bottled or supplied through a compressed-air system. Contaminants shall be filtered out of the air supply.

#### 8.2.6.1.8 Propane

The gas supplied to the burner shall be CP-grade propane (99 percent pure) having a nominal heating value of 93.0 MJ/m<sup>3</sup> or 22.2 kilocalories (thermochemical)/m<sup>3</sup> [2500 Btu (thermochemical) /ft<sup>3</sup>].

#### 8.2.6.1.9 Gas flows

The propane flow shall be  $220 \pm 8$  cm<sup>3</sup>/s ( $28 \pm 1$  ft<sup>3</sup>/hr) when corrected to standard temperature and pressure (20°C, 101 kPa).

The airflow shall be  $1280 \pm 80$  cm<sup>3</sup>/s ( $163 \pm 10$  ft<sup>3</sup>/hr) when corrected to standard temperature and pressure.

#### 8.2.6.1.10 Smoke-measuring instruments

The photometer system shall consist of a light source and photoelectric cell mounted on a horizontal section of the exhaust duct at a point at which the system is preceded by a straight run of duct that is at least twelve duct diameters or 4.88 m (16 ft) long, to ensure a nearly uniform velocity of flow across the duct cross-section. Positioning of the photometer system at another location shall be optional if it is shown that equivalent results are obtained. The light beam shall be directed horizontally along the diameter of the duct. A photoelectric cell whose output is directly proportional to the amount of light received shall be mounted over the light source and shall be connected to a recording device having an accuracy within  $\pm 1$  percent of full scale for indicating changes in the attenuation of incident light resulting from the passage of smoke (particulate matter) and other effluents. The distance between the light-source lens and the photocell lens shall be  $914 \pm 51$  mm ( $36 \pm 2$  inches). The cylindrical light beam shall pass through round openings 76 mm (3 inches) in diameter on opposite sides of the 406 mm (16 inches) duct, with the resultant light beam centered on the photocell.

The output signal from the photoelectric cell shall be processed into a continuous record of smoke obscuration, from which the optical density shall be calculated.

#### 8.2.6.1.11 Data acquisition

A digital data-acquisition system shall be used to collect and record smoke and pressure measurements. The speed and capacity of the data system shall result in the collection of data every 5 s.

#### 8.2.6.1.12 Pretest calibration of equipment

Prior to the start of each day of testing, the linearity of the photometer system shall be verified by interrupting the light beam with multiple calibrated neutral-density filters to cover the range of the recording instrument. Transmittance values measured by the photometer, using neutral-density filters, shall be within  $\pm 3$  percent of the calibrated value for each filter.

#### 8.2.6.1.13 Test specimens

##### 8.2.6.1.13.1 Cable mounting

Two sets of specimens of each cable construction shall be tested [see Clause 5.12.6.2(d) concerning the testing of a third set]. Each set shall consist of multiple 2.44 m (96 inches) lengths of the finished cable.

The specimen lengths of cable shall be fastened in a single layer in the tray, by means of steel or copper wire not larger than 2.08 mm<sup>2</sup> (14 AWG), at their upper and lower ends and at two other equally spaced points along their lengths, with each cable vertical. As many cables shall be installed in the tray as will fit when spaced one-half cable diameter apart, filling the center 150 mm (6 inches) of the tray width. The number of specimen lengths to be tested is to be determined as

$$N = (102/D_{\text{mm}}) + 0.33$$

$$N = (4/D_{\text{inches}}) + 0.33$$

where

N is the number of cables (rounded up to the nearest whole number);

D is the diameter of the cable in millimeters (inches).

For a flat cable, the cable diameter shall be an equivalent diameter calculated as

$$D = 1.1284 \times (TW)^{1/2}$$

where

T is the length of the minor axis of the flat cable;

W is the length of the major axis of the flat cable.

#### 8.2.6.1.13.2 **Conditioning**

Before the test is started, the test specimens shall be conditioned for at least 3 h in air whose temperature is  $23 \pm 5^{\circ}\text{C}$  ( $73 \pm 9^{\circ}\text{F}$ ). The test chamber shall be dry.

#### 8.2.6.1.14 **Test procedure**

##### 8.2.6.1.14.1 **Initial preparation**

At the start of the test, the cables, apparatus, and the air in the test area shall be in thermal equilibrium with one another at a temperature of at least  $5^{\circ}\text{C}$  ( $41^{\circ}\text{F}$ ).

The pretest calibration procedure described in Clause 8.2.6.1.12 shall be performed.

Power shall be applied to the digital data-acquisition equipment and to the computer.

A nominal exhaust flow rate of  $0.65 \pm 0.05 \text{ m}^3/\text{s}$  ( $23.0 \pm 1.8 \text{ ft}^3/\text{s}$ ) shall be established in the duct.

##### 8.2.6.1.14.2 **Procedure**

The prepared cable tray shall be positioned vertically inside the enclosure, with the open front of the cable tray facing the front of the enclosure. The cable tray shall be firmly secured in position.

The burner shall be ignited and the gas flows shall be adjusted to the values indicated in Clause 8.2.6.1.9. The burner shall be positioned behind the cable tray and  $75 \pm 5 \text{ mm}$  ( $3.0 \pm 0.2 \text{ inches}$ ) from the nearest cable surface.

The burner flame shall impinge on the specimens for a continuous period of 20 min.

At the end of the 20 min burn, the burner flame shall be extinguished and the cable fire (if any) shall be allowed to burn itself out.

Note shall be taken and a record kept of the flame height during the 20 min test, as well as the time in seconds that the cables continue to flame following removal of the burner flame.

The test procedure shall be conducted on the number of sets of cable specimens specified. Each procedure (burn) shall be conducted on previously untested specimens.

#### 8.2.6.1.14.3 Evaluation of damage

The maximum height of damage on the cables shall be determined by measuring the blistering, char, and other damage upward from the bottom of the vertical tray, but ignoring soot that can be removed with a cloth, after the cables and tray have cooled to room temperature.

The limit of char shall be determined by pressing against a number of points on the cable surfaces with a sharp object. Where a cable surface (outer jacket, if any) changes from resilient to brittle (crumbling), the limit of char has been determined. Distortion of the outer surface of the cable, such as blistering or melting immediately above the char, shall be included in the damage measurement.

The cable damage shall be recorded to the nearest 25 mm (1 inch).

#### 8.2.6.1.15 Calculation of smoke release rate

The smoke release rate (SRR) shall be calculated using the optical density per linear path length in the duct and the volumetric flow rate. The following equation is to be used to determine the SRR:

$$\text{SRR} = \frac{(\text{OD} \times M_1)}{0.4064}$$

where

SRR is the smoke release rate in meters squared per second;

OD is the optical density;

$M_1$  is the volumetric flow rate (in cubic meters per second) in the exhaust duct referred to 298K;

0.4064 is the path length in the duct in meters.

#### 8.2.6.1.16 Report

The test report shall contain the following summary information:

- a) A description of each set of specimens tested: the cable type letters and component makeup and the number of cable lengths in the set;
- b) The number of burns;
- c) The date on which the test was conducted.

#### 8.2.6.2 Alternate vertical-tray fire propagation and smoke release (FT4/IEEE 1202) (ST1)

##### 8.2.6.2.1 Apparatus

The test apparatus shall include the following main components:

- a) Ignition source;
- b) Collection hood and exhaust duct;
- c) Velocity-measuring instrumentation;
- d) Smoke-measuring instruments;
- e) Data-acquisition system.

The cable test enclosure shall be located in a test building that has vents for the discharge of the combustion products and also has provisions for fresh-air intake.

##### 8.2.6.2.2 Cable test enclosure and exhaust duct

The enclosure in which the cables are tested shall be as shown in Figure 1. The use of other enclosures shall be optional if they are shown to provide equivalent results and are of a size  $2.4 \text{ m}^3$  (8 ft<sup>3</sup>) or  $3 \text{ m}^3$  such that the internal volume of the enclosure, exclusive of the pyramidal hood, is not less than  $14.5 \text{ m}^3$  (512 ft<sup>3</sup>) or greater than  $36 \text{ m}^3$  (1272 ft<sup>3</sup>), the floor area is not smaller than  $6 \text{ m}^2$  (64 ft<sup>2</sup>) or larger than  $9 \text{ m}^2$  (97 ft<sup>2</sup>), and the maximum air movement within the enclosure complies with Clause 8.2.6.2.3.

The walls of the structure shall be of concrete masonry having a density of  $1698 \text{ kg/m}^3$  (106 lb/ft<sup>3</sup>) and a thermal conductivity  $k$  at  $21.1^\circ\text{C}$  [ $70.0^\circ\text{F}$ ] of  $0.055 \text{ W}/(\text{m}\cdot\text{K})$  [ $0.38 \text{ Btu (thermochemical)}\cdot\text{in}/(\text{hr}\cdot\text{ft}^2\cdot^\circ\text{F})$ ], with the interior surface painted flat black. The walls shall contain window(s), as shown in Figure 1, for observation of the fire test. Alternative construction materials for the structure walls shall meet the intent of this requirement if both of the following conditions are met:

- a) The overall thermal conductivity, based on an inside wall temperature of  $37.8^\circ\text{C}$  ( $100.0^\circ\text{F}$ ) and an outside air temperature of  $23.9^\circ\text{C}$  ( $75.0^\circ\text{F}$ ), is  $0.072 \pm 0.043 \text{ W}/(\text{m}\cdot\text{K})$  [ $0.50 \pm 0.30 \text{ Btu (thermochemical)}\cdot\text{in}/(\text{hr}\cdot\text{ft}^2\cdot^\circ\text{F})$ ];
- b) The construction materials withstand the high temperatures and open flame in the test enclosure.

The enclosure shall contain a steel access door. The door shall be provided with a wired-glass window and shall be located as shown in Figure 1. The door and hood shall have an overall thermal conductivity equal to that of the walls. Alternative construction materials shall meet the intent of these requirements if equivalent thermal conductivity is obtained.

A truncated-pyramid steel hood and a collection box, each formed as shown in Figure 1, shall be located on top of the enclosure walls. Compressible inorganic batting shall be used as a gasket between the hood and the walls.

The exhaust duct connected to the plenum on the hood shall consist of a steel pipe 406 mm (16 inches) in inside diameter, installed horizontally, as shown in Figure 1.

#### 8.2.6.2.3 Velocity-measuring instruments

The velocity in the exhaust duct shall be determined by measuring the differential pressure in the flow path with the bi-directional probe shown in Figure 2. The probe shall be connected to an electronic pressure gauge or an equivalent measuring system. The probe shall be 44 mm (1.75 inches) long and shall have an outside diameter of 22 mm (0.875 inch). The pressure taps (tubes) on either side of the diaphragm shall support the probe.

The axis of the probe shall be located on the centerline of the duct a minimum of 4.0 m (13 ft, 4 inches) downstream from the last turn in the duct, to ensure a nearly uniform velocity of flow across the duct cross-section. The positioning of the probe at another location shall be optional if it is shown that equivalent results are obtained. The pressure taps shall be connected to a pressure transducer having a minimum resolution of 0.025 Pa (0.001 lb/in<sup>2</sup>).

The temperature of the exhaust gas shall be measured approximately 152 mm (6 inches) upstream from the probe on the centerline of the duct, using a 0.08 mm<sup>2</sup> (28 AWG) Type K thermocouple having an inconel sheath.

The maximum air movement in the inlets at the floor of the enclosure, with the exhaust fan on, shall not exceed 1 m/s (3.3 ft/s).

The maximum air movement within the enclosure, with only the intake and exhaust openings open, the exhaust fan on (if applicable), and the burner off, shall not exceed 1 m/s (3.3 ft/s), as measured in each of the following areas by means of a vane anemometer:

- a) On the floor of the enclosure at the position occupied by the burner during the test;
- b) 1.5 m (4.9 ft) above the floor of the enclosure at the position occupied by the cable tray during the test.

#### 8.2.6.2.4 Cable tray

A steel ladder type of cable tray as shown in Figure 4, clean and free of residue and debris, shall be used. The rungs shall be attached to the inside of the side channels. The tray shall be arranged so that the burner flame impinges on the cables midway between rungs.

#### 8.2.6.2.5 Burner

The test flame shall be supplied by means of a strip or ribbon type of propane-gas burner. The flame-producing surface (face) of the burner shall consist essentially of a flat metal plate that is 341 mm (13-7/16 inches) long x 30 mm (1-5/32 inches) wide. The plate shall have an array of 242 holes drilled in it. The holes shall be 1.35 mm (1.35 mm metric drill size) [0.052 inch (No. 55 drill)] in diameter and shall be on 3.2 mm (0.125 inch) centers in three staggered rows of 81, 80, and 81 holes each, to form an array measuring 257 mm (10-1/8 inches) by 5 mm (3/16 inch). The array of holes shall be centered on the plate. See Figure 3 and footnote to Clause 8.2.6.1.5.

The burner shall be mounted on a stand and angled  $20^\circ \pm 2^\circ$  from the horizontal with the burner ports up (see Figure 4). The top of the burner shall be located  $305 \pm 25$  mm ( $12 \pm 1$  inches) above the base of the cable tray and parallel to the cable-tray rungs. A guide shall be attached to the burner or stand so that the leading edge of the burner face can be accurately placed  $76 \pm 5$  mm ( $3.0 \pm 0.2$  inches) horizontally from the nearest surface of the cables.

#### 8.2.6.2.6 Flowmeters

A flowmeter shall be inserted in each of the propane and air lines feeding the burner, to measure the flow rates of these gases during the test.

The propane flowmeter shall be capable of measuring a flow rate of  $2.3 \times 10^{-4}$  m<sup>3</sup>/s (29 ft<sup>3</sup>/hr), and the air flowmeter  $13.3 \times 10^{-4}$  m<sup>3</sup>/s (170 ft<sup>3</sup>/hr). Measurements shall be accurate within 3 percent. A mass flow controller with recorded output shall be optional.

#### 8.2.6.2.7 Air

The air supplied to the burner shall be compressed air, either bottled or supplied through a compressed-air system. Contaminants shall be filtered out of the air supply.



#### 8.2.6.2.8 Propane

The gas supplied to the burner shall be CP-grade propane (99 percent pure) having a nominal heating value of 93.0 MJ/m<sup>3</sup> or 22.2 kilocalories (thermochemical)/m<sup>3</sup> [2500 Btu (thermochemical) /ft<sup>3</sup>].

#### 8.2.6.2.9 Gas flows

The propane flow shall be 220 ±8 cm<sup>3</sup>/s (28 ±1 ft<sup>3</sup>/hr) when corrected to standard temperature and pressure (20°C, 101 kPa).

The airflow shall be 1280 ±80 cm<sup>3</sup>/s (163 ±10 ft<sup>3</sup>/hr) when corrected to standard temperature and pressure.

#### 8.2.6.2.10 Smoke-measuring instruments

The photometer system shall consist of a light source and photoelectric cell mounted on a horizontal section of the exhaust duct at a point at which the system is preceded by a straight run of duct that is at least twelve duct diameters or 4.88 m (16 ft) long, to ensure a nearly uniform velocity of flow across the duct cross-section. The light beam shall be directed horizontally along the diameter of the duct. A photoelectric cell whose output is directly proportional to the amount of light received shall be mounted over the light source and shall be connected to a recording device having an accuracy within ±1 percent of full scale for indicating changes in the attenuation of incident light resulting from the passage of smoke (particulate matter) and other effluents. The distance between the light-source lens and the photocell lens shall be 914 ±51 mm (36 ±2 inches). The cylindrical light beam shall pass through round openings 76 mm (3 inches) in diameter on opposite sides of the 406 mm (16 inches) duct, with the resultant light beam centered on the photocell.

The output signal from the photoelectric cell shall be processed into a continuous record of smoke obscuration, from which the optical density shall be calculated.

#### 8.2.6.2.11 Data acquisition

A digital data-acquisition system shall be used to collect and record smoke and pressure measurements. The speed and capacity of the data system shall result in the collection of data every 5 s.

#### 8.2.6.2.12 Pretest calibration of equipment

Prior to the start of each day of testing, the linearity of the photometer system shall be verified by interrupting the light beam with multiple calibrated neutral-density filters to cover the range of the recording instrument. Transmittance values measured by the photometer, using neutral-density filters, shall be within  $\pm 3$  percent of the calibrated value for each filter.

#### 8.2.6.2.13 Test specimens

##### 8.2.6.2.13.1 Cable mounting

Two sets of specimens of each cable construction shall be tested [see Clause 5.12.6.3(d) concerning the testing of a third set]. Each set shall consist of multiple 244 cm (96 inches) lengths of the finished cable. Depending upon the outside diameter of the individual cable, the test specimens shall be either separate, individual lengths or a bundle of individual lengths. The specimens or specimen bundles shall be centered between the side rails in a single layer. The lower end of each specimen or specimen bundle shall be located not more than 100 mm (4 inches) above the bottom end of the cable tray. Each specimen or specimen bundle shall be separately attached to each rung of the cable tray, using one wrap of copper or steel wire not larger than 2.08 mm<sup>2</sup> (14 AWG) in accordance with the following:

- a) CABLES SMALLER THAN 13 mm: For cables smaller in diameter than 13 mm (0.51 inch), the specimens shall be grouped into untwisted bundles (nominally circular) as indicated in Table 37. The bundles shall be spaced one-half bundle diameter apart on the cable tray as measured at the point of attachment to the cable tray.
- b) CABLES 13 mm AND LARGER: For cables 13 mm (0.51 inch) and larger in diameter, each specimen shall be individually attached to the cable tray with a separation of one-half cable diameter or 15 mm (0.59 inch) (whichever is less) between specimens. The tray loading shall comply with Table 38.
- c) FLAT CABLES: For a flat cable, the equivalent cable diameter shall be calculated using the following formula:

$$D = 1.128 \times (TW)^{1/2}$$

where

D is the calculated cable diameter;

T is the length of the minor axis of the cable;

W is the length of the major axis of the cable.

#### 8.2.6.2.13.2 **Conditioning**

Before the test is started, the test specimens shall be conditioned for at least 3 h in air whose temperature is  $23 \pm 5^\circ\text{C}$  ( $73 \pm 9^\circ\text{F}$ ). The test chamber shall be dry.

#### 8.2.6.2.14 **Test procedure**

##### 8.2.6.2.14.1 **Initial preparation**

At the start of the test, the lengths of cable in the tray, the apparatus, and the air in the test area shall be in thermal equilibrium with one another at a temperature of at least  $5^\circ\text{C}$  ( $41^\circ\text{F}$ ).

The pretest calibration procedure described in Clause 8.2.6.2.12 shall be performed.

Power shall be applied to the digital data-acquisition equipment and to the computer.

A nominal exhaust flow rate of  $0.65 \pm 0.05 \text{ m}^3/\text{s}$  ( $23.0 \pm 1.8 \text{ ft}^3/\text{s}$ ) shall be established in the duct.

##### 8.2.6.2.14.2 **Procedure**

The prepared cable tray shall be positioned vertically inside the enclosure, with the open front of the cable tray facing the front of the enclosure. The cable tray shall be firmly secured in position.

The burner shall be ignited and the gas flows shall be adjusted to the values indicated in Clause 8.2.6.2.9. The burner shall be positioned in front of the cable tray at an angle of  $20^\circ$  and  $75 \pm 5 \text{ mm}$  ( $3.0 \pm 0.2 \text{ inches}$ ) from the nearest cable surface. See Figure 4 for the relative positions of the cable tray and burner in the room.

The burner flame shall impinge on the specimens for a continuous period of 20 min.

At the end of the 20 min burn, the burner flame shall be extinguished and the cable fire (if any) shall be allowed to burn itself out.

Note shall be taken and a record kept of the flame height during the 20 min test, as well as the time in seconds that the cables continue to flame following removal of the burner flame.

The test procedure shall be conducted on the number of sets of cable specimens specified. Each procedure (burn) shall be conducted on previously untested specimens.

#### 8.2.6.2.14.3 Evaluation of damage

The maximum height of damage to the cables shall be determined by measuring the blistering, char, and other damage upward from the lower edge of the burner face, but ignoring soot that can be removed with a cloth, after the cables and tray have cooled to room temperature.

The limit of char shall be determined by pressing against a number of points on the cable surfaces with a sharp object. Where a cable surface (outer jacket, if any) changes from resilient to brittle (crumbling), the limit of char has been determined. Distortion of the outer surface of the cable, such as blistering or melting immediately above the char, shall be included in the damage measurement.

The cable damage shall be recorded to the nearest 25 mm (1 inch).

#### 8.2.6.2.15 Calculation of smoke release rate

The smoke release rate (SRR) shall be calculated using the optical density per linear path length in the duct and the volumetric flow rate. The following equation shall be used to determine the SRR

$$\text{SRR} = \frac{(\text{OD} \times M_1)}{0.4064}$$

where

SRR is the smoke release rate in meters squared per second;

OD is the optical density;

$M_1$  is the volumetric flow rate (in cubic meters per second) in the exhaust duct referred to 298K;

0.4064 is the path length in the duct in meters.

#### 8.2.6.2.16 Report

The test report shall contain the following summary information:

- a) A description of each set of specimens tested: the cable type letters and component makeup and the number of cable lengths in the set;
- b) The number of burns;
- c) The date on which the test was conducted.

### 8.2.7 LS (low smoke): flame, smoke, and acid gas release

#### 8.2.7.1 Smoke emission

##### 8.2.7.1.1 General

This test establishes the method for determining the specific optical density and smoke obscuration generated by electrical conductors with an overall diameter no greater than 10 mm (0.40 inch) and in plaques 2 mm (0.08 inch) thick, for their individual components, and for cables with an overall diameter greater than 25.4 mm (1 inch).

##### 8.2.7.1.2 Apparatus and equipment

The following apparatus shall be required:

- a) Smoke density chamber, with integral or separate graphing capability (see Figure 5);
- b) Insulated leather gloves;
- c) Spatula;
- d) Pliers;
- e) Scissors;
- f) Aluminum foil  $0.038 \pm 0.001$  mm ( $0.0015 \pm 0.000040$  inch) thick;
- g) Flannel cloth;
- h) Ethyl alcohol.

### 8.2.7.1.3 Preparation of samples

#### 8.2.7.1.3.1 Number of sets of samples

A minimum of three sets of samples shall be required.

#### 8.2.7.1.3.2 Size

The size of the specimens shall be adjusted to the dimensions of the trays used in the smoke chamber, which are cut squares 75 mm x 75 mm (3 inches x 3 inches), prepared in one of two of the following forms, as applicable:

- a) A plaque  $2 \pm 0.2$  mm ( $0.08 \pm 0.008$  inch) in thickness;
- b) Samples from the finished product, with an overall diameter no greater than 10 mm (0.4 inch).

#### 8.2.7.1.3.3 Conditioning

The test material shall be left in a dry environment for 24 h at  $60 \pm 3^\circ\text{C}$  ( $140 \pm 5^\circ\text{F}$ ) and afterwards set in balanced conditions at a room temperature of  $23 \pm 3^\circ\text{C}$  ( $73 \pm 5^\circ\text{F}$ ) and a relative humidity of  $50 \pm 5$  percent.

#### 8.2.7.1.3.4 Mounting

Place the test material in the tray in the following manner:

- a) Wrap the sample with a sheet of aluminum foil, leaving the opaque part in contact with the sample.
- b) Carefully cut the foil to leave free the surface that will be exposed during the test.
- c) Place the inorganic thermal insulation plaque of the tray in the rear and adjust the sample with the clamp.

### 8.2.7.1.4 Procedures

#### 8.2.7.1.4.1 Preparation and start-up of equipment

The following requirements shall apply:

- a) Cleaning: the smoke chamber, and particularly the viewing area of the optical system, shall be free of contaminants and shall be cleaned using ethyl alcohol or other adequate cleaner.
- b) Characteristics of gas: the gas provided to the chamber shall be a mixture of compressed air and propane having the following characteristics:
  - i) Filtered compressed air: for radiometric calibration of the electrical voltage of the oven, compressed air  $0.103 - 0.172$  MPa ( $710 - 1185$  lbf/in<sup>2</sup>) shall be required, to maintain the temperature of the radiometer casing at  $93 \pm 3^\circ\text{C}$  ( $200 \pm 5^\circ\text{F}$ ). During the test, a constant flow of  $500$  cm<sup>3</sup>/min ( $30$  in<sup>3</sup>/min) shall be required.
  - ii) Propane that is 95 percent pure, maintaining its flow at  $50$  cm<sup>3</sup>/min ( $3$  in<sup>3</sup>/min) inside the chamber over the course of the test, shall be required.

c) Sealing: close the smoke extraction system, the ventilation window, and the chamber door. Pressurize the chamber until reaching 7.62 cm (3 inches) of water, introducing air through the (flame air) duct (see [1] of Figure 5), and taking the measurement with a pressure gauge. Cut off the entrance of air and measure the time to lower the pressure to 5.08 cm (2 inches) water on the pressure gauge, which shall not take less than 5 min.

If the chamber does not adequately maintain pressure, the safety seal of aluminum foil shall be changed (see [2] of Figure 5).

d) Position of trays: the tray shall be placed in front of the oven, and shall contain the inorganic thermal insulation plaque only during the heating of the chamber.

e) Heating of the smoke chamber: in order to reach the test temperature in the chamber, perform the following:

- i) Connect the equipment.
- ii) Close the smoke extraction system (see [7] of Figure 5).
- iii) Open the ventilation window (see [8] of Figure 5).
- iv) Turn on the equipment switch (see [9] of Figure 5).
- v) Close the lamp switch (see [5] of Figure 5).
- vi) Turn on the microphotometer, placing the graphing pen at 100 percent transmittance, using the fine-adjustment knob. Variations in the adjustments are normal; therefore, before initiating the test, it shall be adjusted again to 100 percent.
- vii) Close the heating switch (see [10] of Figure 5), and gradually heat using the electrical voltage adjustment knob (see [11] of Figure 5), until reaching the necessary corresponding voltage at the previous oven calibration, to obtain a radiation potency of  $2.5 \pm 0.05 \text{ W/cm}^2$  ( $16.1 \pm 0.3 \text{ W/in}^2$ ).
- viii) Once the aforementioned conditions are established, permit a minimum heating time of 1 h so that the measurement of the temperature of the chamber (see [12] of Figure 5); reaches  $35 \pm 2^\circ\text{C}$  ( $95 \pm 4^\circ\text{F}$ ), which is the test temperature.

#### 8.2.7.1.4.2 Calibration of optical system

To calibrate the optical system, perform the following procedures:

- a) Verify that the choke of the photomultiplier tube (see [3] of Figure 5) is closed, that the ND-2 filter (see [4] of Figure 5) is in position of the light trajectory, and that the lamp switch is closed (see [5] of Figure 5).
- b) Verify that the positions of the photomultiplier switches (see [6] of Figure 5) are as follows:
  - i) Starter switch on;
  - ii) Multiplier switch set to 100;
  - iii) Relative intensity switch on.
- c) Adjust to 0 percent transmittance on the scale, with the obscuration knob at zero, until reaching a stable zero reading in each one of the multiplier scales.
- d) Reset the multiplier on 100.
- e) Open the stopper of the photomultiplier tube.
- f) Adjust one stable reading from 100 percent transmittance, using the relative intensity knob.
- g) When the plotter is used (at 50 mV plus 100 scale), adjust the recorder that exists at the rear of the photomultiplier so that the reading of 100 is placed in the desired position on the plotter.

#### 8.2.7.1.4.3 Calibration of oven

Once the temperature of the wall of the chamber reaches  $35 \pm 2^{\circ}\text{C}$  ( $95 \pm 4^{\circ}\text{F}$ ), calibrate the potency of radiation from the oven by using the radiometer in accordance with the following procedure:

- a) Connect a high-impedance 10 mV meter or grapher to the contacts located on the switchboard (see [13] of Figure 5).
- b) Place the radiometer on the support bars near the tray.
- c) Place the thermometer on the radiometer.
- d) Remove the top of the electrical connector from the radiometer on the floor of the chamber; connect the air tube from the radiometer and the electrical conductor to the appropriate connections.
- e) Place the radiometer directly in front of the oven, setting aside the trays that contain the inorganic thermal insulation plaque, and close the door of the chamber.
- f) When the thermometer reads between  $81^{\circ}\text{C}$  and  $87^{\circ}\text{C}$  ( $178^{\circ}\text{F}$  and  $189^{\circ}\text{F}$ ), open the air valve from the radiometer, adjusting the volume with the needle valve.



- g) Stabilize the temperature to  $93 \pm 3^{\circ}\text{C}$  ( $200 \pm 5^{\circ}\text{F}$ ) and take the signal reading of the radiometer from the meter or grapher. This value shall be equal to the value specified in the inspection report provided by the radiometer supplier or to the re-calibration value, with a tolerance of  $\pm 0.05$  mV.
- h) Turn the electrical voltage adjustment knob until the meter or grapher shows the value specified in Item g). After each adjustment, allow the desired reading to remain steady for 10 min.
- i) When the millivolt level has been calibrated to  $\pm 0.05$  mV, and with the thermometer indicating  $93 \pm 3^{\circ}\text{C}$  ( $200 \pm 5^{\circ}\text{F}$ ), ensure that the radiation potency of the oven is equal to  $2.5$   $\text{W}/\text{cm}^2$  ( $16.1$   $\text{W}/\text{in}^2$ ).
- j) If necessary, vary the air flow and the oven's electrical voltage in order to achieve stability in oven radiation, maintaining the temperature at  $93 \pm 3^{\circ}\text{C}$  ( $200 \pm 5^{\circ}\text{F}$ ).
- k) Record the air flow, the electrical voltage applied to the oven in volts, and the temperature of the chamber. Ensure that the voltage applied to the oven is kept steady during the entire test, until it is re-calibrated again.
- l) Remove the radiometer from in front of the oven.
- m) Shut off the air flow.
- n) Remove the air connections from the radiometer and from the electrical conductor.
- o) Remove the radiometer from the chamber.
- p) Place the top back on the electrical conductor connection in the bottom of the chamber.

#### 8.2.7.1.4.4 Installation and lighting of the gas burner

Perform the following procedures:

- a) Center the trays having the inorganic thermal insulation plaque in front of the oven.
- b) Connect the burner to the air/propane line of the chamber and tighten the connection.
- c) Make sure that the position of the horizontal burners is  $6.35$  mm ( $0.25$  inch) above the opening of the trays and is at a distance of  $6.35$  mm ( $0.25$  inch) horizontally from the trays. Tighten the nut.
- d) Open the valve of the burner (see [15] of Figure 5).
- e) Light the burner and adjust the flow to  $50$   $\text{cm}^3/\text{min}$  ( $3$   $\text{in}^3/\text{min}$ ) and open the air valve of the burner until reaching  $500$   $\text{cm}^3/\text{min}$  ( $30$   $\text{in}^3/\text{min}$ ).

### 8.2.7.1.5 Test procedure

#### 8.2.7.1.5.1 Before initiating the evaluation of one sample, verify the following:

- a) The conditions of the smoke chamber are stable.
- b) The oven and the burner or pilot have been calibrated, and the air/gas flows are in accordance with the values obtained during the calibration.
- c) The preparation and mounting of the samples in the trays are completely vertical, to avoid erroneous results.

#### 8.2.7.1.5.2 Initiate the test under the following procedure:

- a) Turn the handle from the smoke extraction system to the closed position (See [16] of Figure 5).
- b) Make sure that the ventilation window is completely closed when the photomultiplier indicates the presence of smoke.

**Note:** *The pressure increase in the chamber due to combustion changes the air and propane flows of the flame, making it necessary to readjust the values specified to maintain the correct flow.*

- c) Place the trays with one or more test specimens with the inorganic thermal insulation plaque.
- d) Push the tray with the test specimen(s) toward the front of the oven using the positioning knob (see [17] of Figure 5).
- e) Immediately activate the grapher and close the door to the chamber.
- f) Completely close the ventilation window when the photomultiplier indicates a reduction in the percentage of transmittance.
- g) Upon the reduction of percentage of transmittance, increase the sensitivity of the microphotometer when the indicator is lowered to 10 percent, which will require making the change for each scale. If the level of transmittance falls to one-quarter scale, cover the window of the door to avoid effect in the measurement coming from the outside.
- h) To record sensitivity under the 0.1 scale, take the following into account:
  - i) Change the photomultiplier to the 1 scale.
  - ii) Remove the ND-2 filter from the lighted trajectory.
  - iii) In the case where the 10 percent scale is reached, change the photomultiplier to the 0.1 scale
- i) Continue the test for 3 minutes after the minimum transmittance, or after 20 minutes of testing, whichever occurs first.

8.2.7.1.5.3 To end the test, do the following:

- a) Stop the plotter.
- b) Return the scale to 100.
- c) Purge the chamber by opening the smoke extraction system and the ventilation window.
- d) Measure the final transmittance after purging and before cleaning the chamber.
- e) Remove the trays when the smoke has been extracted and let them cool.
- f) Allow the chamber to ventilate for a few minutes to make sure maximum transmittance has been achieved.
- g) Clean the optical system windows with ethyl alcohol.

8.2.7.1.5.4 To test remaining samples, repeat the previous procedure.

When the results for any of the three sets of prepared samples are such that they exceed the minimum result by more than 50 percent without any apparent reason, three other sets of additional samples shall be tested, and the average of the six samples tested shall be reported.

If one or more of the three tests show any abnormal results, such as the sample falling from the tray, melted material totally covering the tray, spontaneous combustion, temporary extinguishing of the flame, or movement of the sample from the irradiation zone, three other sets of additional samples shall be tested, and in this case only the results of the tests that do not show these problems shall be reported.

#### 8.2.7.1.6 Calculations

With the values of percent transmittance obtained from the graph during each minute of the test, the specific optical densities shall be determined, using Table 39.

The maximum specific optical density  $D_m$  corresponds to the minimum percent transmittance.

The optical value at the first 4 minutes  $VOF_4$  (smoke obscuration value) is calculated using the following formula:

$$VOF_4 = d_1 + d_2 + d_3 + \frac{d_4}{2}$$

where

$d_1$ ,  $d_2$ ,  $d_3$ , and  $d_4$  are the corresponding specific optical densities at each of the first 4 min.

### 8.2.7.2 Fire propagation

#### 8.2.7.2.1 Equipment and instruments

##### 8.2.7.2.1.1 Chamber

The dimensions of the chamber shall be in accordance with Figure 6, and shall contain the following:

- a) Three doors, packed to provide a hermetic seal;
- b) Windows installed in each of the doors;
- c) Vents located at the lower ends of the lateral doors, which regulate air velocity;
- d) Metallic structure that permits vertical sliding of the electrical oven in a manner that allows for 2 positions (upper and lower). Dimensions are illustrated in Figure 7 and Figure 8;
- e) Extractor mounted in the upper end of the chamber, whose intake shall be located along the chamber axis;
- f) Electrical oven comprising essentially a tube of aluminum silicate having an inside diameter of  $100 \pm 3$  mm (4 inches), an outside diameter of  $115 \pm 3.5$  mm (4-1/2 inches), and a length of  $203 \pm 6$  mm (8 inches), on which a  $1.30 \text{ mm}^2$  (16 AWG) ceramic insulated nickel-chromium resistance wire is wound;
- g) Power supply that delivers required current;
- h) Two gas burners provided with a V-shaped deflector in accordance with Figure 9. The burners shall produce a flame  $15 \text{ mm} \pm 5 \text{ mm}$  ( $0.6 \pm 0.2$  inch) in diameter and a blue cone  $20 \text{ mm} \pm 5 \text{ mm}$  ( $0.8 \pm 0.2$  inch) in length, and shall be fixed in a mechanism that keeps a constant distance E in conformance with the test procedures;
- i) Metallic chimney with an internal diameter of between 120 and 125 mm (4.8 and 5 inches) along the same axis as the oven, attached to the metallic structure and at  $30 \text{ mm} \pm 1 \text{ mm}$  ( $1.2 \pm 0.04$  inches) above the high position of the oven, and having three series of slots in the periphery, separated  $120^\circ$  as indicated in Figure 10;
- j) Stainless steel tube with the dimensions indicated in Figure 11;

- k) Thermometer to measure the temperature; a pyrometer with a range of 0 – 1200°C (32 – 2192°F) that includes an adequate thermocouple attached to the stainless steel tube shall be used;
- l) Copper bar with 99 percent or greater purity and with measurements in accordance with Figure 12;
- m) Insulation millboard that completely covers the upper end of the oven.

#### 8.2.7.2.1.2 **Anemometer**

An anemometer shall be used for measurement of the velocity of air that passes through the chimney.

#### 8.2.7.2.1.3 **Gas line**

A gas line shall be connected to the burners in the chamber.

#### 8.2.7.2.1.4 **Chronometer**

A chronometer shall be used to measure time intervals.

### 8.2.7.2.2 **Calibration**

#### 8.2.7.2.2.1 **General**

It is recommended that the oven be calibrated every six months, or sooner, depending on the frequency of use. During oven calibration and adjustment of air velocity, the air surrounding the chamber shall be calm and at a temperature greater than 15°C (60°F).

#### 8.2.7.2.2.2 **Calibration of electrical oven**

To calibrate the oven, use the copper bar referred to in Clause 8.2.7.2.2.3. Suspend the bar from the metallic structure in such a way that, when the oven is at its high position, the bar is centered on the axis of the oven and has a temperature between 35°C and 55°C (95°F and 131°F). Slide the oven to its lower position, cover the upper end with the inorganic thermal insulation plaque, and heat it until the temperature measured with the thermocouple attached to the stainless steel bar is stabilized. Stabilization is logged when the temperature recorded does not vary by more than 5°C (9°F) in an hour.

Once the oven temperature has been stabilized, uncover the oven and slide it to its upper position in less than 5 s. Record the temperature rise on the reference bar at 5 s and 35 s. Calculate the rate of temperature rise with the following formula:

$$V = \frac{T_{35} - T_5}{K}$$

where

V is the rate of temperature rise, in °C/s;

T<sub>35</sub> is the recorded temperature after 35 s, in °C;

T<sub>5</sub> is the recorded temperature after 5 s, in °C;

K is the interval between the two measurements, in s = 30 s.

Ensure that the rate of temperature rise is equal to  $3.3 \pm 1^\circ\text{C/s}$  ( $6 \pm 2^\circ\text{F/s}$ ). If the calculated rate is not equal to this, modify the electrical supply of the oven and re-calculate until the correct value is obtained. Once the electrical supply is found to be adequate, re-attach the thermocouple to the stainless steel bar and drop the oven to its lower position.

The temperature that is reached when the oven is stabilized is the stabilized test temperature; it is generally greater than  $780^\circ\text{C}$  ( $1436^\circ\text{F}$ ).

#### 8.2.7.2.2.3 Reference bar

The bar shall be copper greater than 99 percent pure, darkened on all its surface by applying various coats of colloidal graphite paint with a coefficient of emissivity greater than 0.80, or by applying various black layers of smoke by passing the bar over the flame of a candle at least 7 times. The construction of the bar and the thermocouple shall be in accordance with Figure 12.

#### 8.2.7.2.2.4 Adjusting the air velocity

To measure the air velocity, an anemometer with an accuracy of  $\pm 3$  percent and with fins having a diameter of  $95 \text{ mm} \pm 5 \text{ mm}$  ( $3.74 \pm 0.2$  inches) shall be used. The anemometer shall be placed between the bottom of the chimney and the oven in its high position (while it is turned off). The extractor shall be turned on and the lower vents regulated until a velocity of  $120 \pm 10 \text{ m/min}$  ( $394 \pm 33 \text{ ft/min}$ ) is established. The measurement of air velocity shall be the mean of three determinations, each one with a duration of 5 min, performed at 5 min intervals. The measurements shall be made 10 min after the extractor is turned on.

### 8.2.7.2.3 Preparation of specimens

Two identical specimens 1600 mm (63 inches) in length shall be prepared, constructed of one or various conductors of completed product in accordance with the following:

- a) If the diameter of the conductor is larger than 25 mm (1 inch) and less than or equal to 70 mm (2.75 inches), the specimen shall consist solely of a conductor.
- b) If the conductor diameter is greater than 15 mm (0.6 inch) and less than or equal to 25 mm (1 inch), the specimen shall be made up of three conductors tied, arranged in parallel, and held by metallic strands at each end, at a level in the middle of the oven and at a level in the middle part of the chimney. The specimen shall be arranged such that one of the conductors is placed toward the back side of the chamber, according to Figure 13.
- c) If the diameter of the conductor is less than or equal to 15 mm (0.6 inch), the specimen shall be made up of 7, 12, 19, or more conductors tied together such that the total diameter of the bundle falls between 30 – 45 mm (1.2 – 1.75 inches). The bundle shall be twisted as tightly as possible such that the lay of twist is approximately 15 times the diameter of the bundle. It shall be held in accordance with Item b).

### 8.2.7.2.4 Test procedure

Use the following procedure:

- a) It is very important, during testing, that the circulating air surrounding the chamber be calm and at a temperature greater than 15°C (60°F).
- b) With the oven in the low position and the inorganic thermal insulation covering in place, apply heat until the stabilized temperature described in Clause 8.2.7.2.2.2 is reached.
- c) Once having stabilized the oven, tighten the test specimen in a vertical position, with help from the suspension hooks.
- d) Close the chimney, light the burners, and adjust the flame and distance E to the surface of the specimen as calculated by the following formula:

$$E = D + d + 10$$

where

E is the distance between the axes of the flame, in mm;

D is the diameter of the specimen, in mm;

d is the diameter of the flames, in mm.

- e) Remove the inorganic thermal insulation plaque covering from the oven and slide the oven to its upper position in less than 5 s.
- f) Turn on the extractor and start the chronometer.

- g) After 10 min of initiating the test, turn off the extractor for 1 min, after which time, start the extractor again.
- h) After 30 min, slide the oven to its lower position and turn it off, keeping the extractor on.
- i) Turn off the burners and wait until any remaining flame on the specimen is extinguished.

#### 8.2.7.2.5 Results

The specimens tested shall be inspected visually to determine the highest degradation from the bottom end of the chimney. It is very important to mark the specimen at the bottom of the chimney to serve as a reference.

Only the carbonized portion of the specimen shall be considered as having been degraded by the fire. Eventual deposits produced from combustion, as well as melting, softening, and blisters in the insulation caused by the flames and by heating of the conductor, shall be excluded.

If there is doubt as to whether a particular portion shall be taken into account, the specimen shall be cleaned; afterwards, a cut shall be made with a knife in the zone in question. If the insulation is broken or cracked, this shall be considered true damage, and shall be taken into account as a portion that is degraded.

#### 8.2.7.3 Halogen acid gas emission

##### 8.2.7.3.1 Application and requirement

When tested during pyrolysis in accordance with Clauses 8.2.7.3.2 through 8.2.7.3.5, each nonmetallic component of insulated conductor shall not be more than 20 percent (by weight) halogen acid gas (except hydrogen fluoride) when calculated as a corresponding percentage of HCl.

##### 8.2.7.3.2 Apparatus and equipment

8.2.7.3.2.1 The apparatus and components are shown in Figure 14. A detailed illustration of the quartz combustion tube with means for entrance and exit of gases is shown in Figure 15.

8.2.7.3.2.2 Equipment and materials used to qualify gases collected in wash traps shall include the following:

- a) 600 ml and 250 ml beakers;
- b) Pipet;
- c) Volume flask of 500 ml;
- d) 5 ml or 10 ml pipets;
- e) 100 ml volumetric pipets;
- f) 300 ml Bersilius flask;
- g) 25 ml graduated buret;
- h) Universal support;



- i) Pliers for buret;
- j) Potentiometer (mV);
- k) Measuring electrode (silver);
- l) Calomel reference electrode;
- m) Magnetic agitator;
- n) Magnetic bar.

8.2.7.3.2.3 The reactants shall include:

- a) Distilled water;
- b) 0.1 Normal solution of sodium hydroxide (NaOH 0.1 N);
- c) Concentrated nitric acid (HNO<sub>3</sub> 0.1 N);
- d) 0.1 Normal solution of silver nitrate (AgNO<sub>3</sub> 0.1 N);
- e) Chrome solution (dissolve 6 g potassium dichromate in a minimum amount of distilled water and afterward very carefully and slowly add 200 ml of concentrated sulfuric acid).

#### 8.2.7.3.3 Preparation of sample

In order to perform this test, individual component material from the electrical conductor shall be analyzed, taking into account that the portion of this material has not been pre-treated or subjected to any testing.

A quantity of material sufficient for performing at least three tests shall be used.

Any contamination upon the test specimen shall be avoided.

#### 8.2.7.3.4 Procedure

Use the following procedure:

- a) Weigh 0.5 – 1 ±0.001 g of the sample into the crucible (combustion bay).
- b) Install the systems for combustion and capturing of gases in accordance with Figure 14.
- c) Insert the crucible (combustion bay) with the sample inside the combustion tube in such a way that it is aligned in the center of the oven.
- d) Ensure that the wash traps (see item [12] of Figure 14) contain 100 ml of NaOH 0.1 N, and that the second and third traps are provided with a sinterized glass diffuser.
- e) Initiate and stabilize the dry air flow through the system within 110 ±25 ml/min. Take special care to ensure that there are no leaks in the air system. This can be verified when no bubbles form in the packaging of the system when soapy water is applied to it with a brush. Regulate the air flow from the system with the flow controller, and measure the air flow by means of the flowmeter and the chronometer.

- f) Install the heating element (see Figure 14) in the part of the system located between the combustion oven and the first trap of NaOH. Ensure that the heating element maintains a minimum temperature of 150°C on the surface of the glass ducting during the test.
- g) Set the temperature of the oven to 800°C ±10°C within 20°C/min. Once this temperature is reached, maintain it for 20 min and afterward steady the heating system.
- h) At the conclusion of the 20 min period, disconnect the wash flasks (wash traps) from the system, beginning with the one that is furthest from the oven.
- i) Disconnect the dry air flow.
- j) Allow the system to cool.
- k) Remove the crucible (containing solid residue) from the combustion tube, not allowing the solid residue to contaminate the combustion tube.
- l) Combine the contents in the wash traps into a volumetric flask of 500 ml.
- m) Wash the inside of the combustion tube, the wash traps, and the system connections with distilled water, add this volume to the volume from the wash traps, and empty up to 500 ml in the volumetric flask.
- n) Take an aliquot of the 100 ml of the problem solution obtained, placing it into a 300 ml Bersilius flask, and add 1 ml of concentrated nitric acid.
- o) Using a potentiometer, titrate with 0.1 normal silver nitrate solution, steadily agitating during the entire titration.
- p) Construct a graph on millimetric paper for each one of the specimens and null titrations, plotting milliliters on the X axis, and the millivolts recorded from the potentiometer on the Y axis.
- q) For each specimen analyzed, tests equal to that of a blank test (i.e., without a sample) shall be performed in triplicate. Report the average of the three determinations.

### 8.2.7.3.5 Calculations

The quantity of halogen gas (H) shall be expressed in milligrams of hydrogen chloride per gram of sample, or as a percentage of hydrogen chloride follows:

$$H = \frac{36.5 \times (a-b) \times N \frac{V_f}{A}}{m}$$

$$\%HCl = \frac{36.5 \times (a-b) \times N \frac{V_f}{A}}{m \times 10}$$

where

a is the volume of silver nitrate solution used in the determination of the sample (in ml);

b is the volume of silver nitrate solution used in the null test (in ml);

N is the normality of the silver nitrate solution;

m is the mass of the sample (in grams);

$V_f$  is the volumetric flask (500 ml);

A is the aliquot (100 ml).

The volume of silver nitrate solution used in the determination (volume of silver nitrate at the point of equivalency) shall be obtained from the titration graph.

### 8.2.7.3.6 Description of titration

#### 8.2.7.3.6.1 Titration of the sample

Graph 1 illustrates the typical titration curve. In Graph 2, achievement of the point of equivalency is observed (volume of silver nitrate solution assigned in the calculation).

#### 8.2.7.3.6.2 Null titration

The achievement of a curve similar to the one shown in Graph 3 (undefined potential at the beginning of the curve) indicates the absence of halogens in the solution under analysis; in the initial part of the corresponding curve, therefore, there appears to be no defined potential, such as that which is clearly observed to the left of the point of equivalency in Graph 2.

#### Notes:

- 1) For a rapid control test, the combustion tube may be preheated to 800°C, the air flow adjusted, and the crucible containing the specimen advanced slowly into the combustion area. The results of such a test serve only as a guide toward the intended value, not as precise values for the specimen under study.
- 2) Crucibles should be treated for 2 h at the maximum test temperature to be used and should not be employed for more than eight acid tests.
- 3) Cleaning of the sintered glass diffusers using chromic solution is optional.

### Tables

**Table 1**  
**Conductor Sizes and Stranding**  
**(See Clauses 4.1.5.1, 6.1.3.1, and E2.)**

Wire type	Metal	Conductor size range		Assembly
		mm <sup>2</sup>	AWG or kcmil	
THHN or T90 Nylon THWN-2, THWN or TWN75	Copper	2.08 – 507	14 – 1000	Concentric, compressed, and rope lay
	Copper	2.08 – 507	14 – 1000	Compact
	Copper	2.08 – 107	14 – 4/0	Solid and combination unilay
	Copper	2.08 – 13.3	14 – 6	Bunched
	Aluminum	3.31 – 507	12 – 1000	Concentric and compressed
	Aluminum	3.31 – 507	12 – 1000	Compact
	Aluminum	3.31 – 107	12 – 4/0	Solid
	Aluminum	13.3 – 107	6 – 4/0	Combination unilay
TW, TWU, TWU75, THW or TW75, THW-2, THW- LS, THHW, THHW-LS	Copper	2.08 – 1010	14 – 2000	Concentric, compressed, and rope lay
	Copper	2.08 – 507	14 – 1000	Compact
	Copper	2.08 – 107	14 – 4/0	Solid and combination unilay
	Copper	2.08 – 13.3	14 – 6	Bunched

Table 1 Continued on Next Page

**Table 1 Continued**

Wire type	Metal	Conductor size range		Assembly
		mm <sup>2</sup>	AWG or kcmil	
	Aluminum	3.31 – 1010	12 – 2000	Concentric and compressed
	Aluminum	3.31 – 507	12 – 1000	Compact
	Aluminum	3.31 – 107	12 – 4/0	Solid
	Aluminum	13.3 – 107	6 – 4/0	Combination unilay

**Table 2  
Conductor Stranding  
(See Clauses 4.1.5.2.1 and E2.)**

Sizes of wire		Minimum acceptable number of strands		
mm <sup>2</sup>	AWG or kcmil	Combination unilay	Compact stranded <sup>b,c</sup>	All others
2.08 – 8.37	14 – 8	19 <sup>a</sup>	7	7
13.3 – 33.6	6 – 2	19	7	7
42.4 – 107	1 – 4/0	19	18	19
127 – 253	250 – 500	–	35	37
279 – 507	550 – 1000	–	58	61
557 – 760	1100 – 1500	–	–	91
811 – 1010	1600 – 2000	–	–	127

<sup>a</sup> Copper only.

<sup>b</sup> In the United States, conductors with a lesser number of strands shall be allowed, based on an evaluation for connectability and bending. In Canada and Mexico, this note does not apply.

<sup>c</sup> In Canada, single input wire strands shall be in accordance with ASTM B 835 and ASTM B 836. In the United States, conductors with a lesser number of strands shall be allowed, based on an evaluation for connectability and bending. In Mexico, conductors with a lesser number of strands shall be allowed.

**Table 3  
Length of Lay of Strands in a Bunch-Stranded Conductor Twisted as a Single Bunch<sup>a</sup>  
(See Clause 4.1.5.2.4.)**

Size of conductor		Maximum acceptable length of lay	
mm <sup>2</sup>	AWG	mm	in
2.08	14	44	1-3/4
3.31	12	51	2
5.26	10	64	2-1/2
8.37	8	70	2-3/4
13.3	6	86	3-3/8
larger than 13.3	larger than 6	16 times the conductor diameter	

<sup>a</sup> Includes the following bunch-stranded constructions twisted as a single bunch under Classes I, K, and M:

Conductor size		Number of strands in single bunch		
mm <sup>2</sup>	AWG	Class I	Class K	Class M
2.08	14	–	41	104
3.31	12	–	65	–
5.26	10	26	104	–
8.37	8	41	–	–
13.3	6	65	–	–

**Table 4**  
**Diameters over Solid Conductors and Cross-Sectional Area for All Solid and Stranded**  
**Conductors**  
**(See Clause 4.1.6.1.)**

Size of conductor		Nominal diameter of solid conductor		Nominal cross-sectional area of conductor	
mm <sup>2</sup>	AWG or kcmil	mm	mils	mm <sup>2</sup>	cmil or kcmil
2.08	14 AWG	1.63	64.1	2.08	4110 cmil
3.31	12	2.05	80.8	3.31	6530
5.26	10	2.588	101.9	5.261	10380
8.37	8	3.264	128.5	8.37	16510
13.3	6	4.115	162.0	13.3	26240
21.2	4	5.189	204.3	21.2	41740
26.7	3	5.827	229.4	26.67	52620
33.6	2	6.543	257.6	33.6	66360
42.4	1	7.348	289.3	42.4	83690
53.5	1/0	8.252	324.9	53.5	105600
67.4	2/0	9.266	364.8	67.4	133100
85.0	3/0	10.40	409.6	85.0	167800
107	4/0	11.68	460.0	107	211600
127	250 kcmil	—	—	127	250 kcmil
152	300	—	—	152	300
177	350	—	—	177	350
203	400	—	—	203	400
228	450	—	—	228	450
253	500	—	—	253	500
279	550	—	—	279	550
304	600	—	—	304	600
329	650	—	—	329	650
355	700	—	—	355	700
380	750	—	—	380	750
405	800	—	—	405	800
456	900	—	—	456	900
507	1000	—	—	507	1000
557	1100	—	—	557	1100
608	1200	—	—	608	1200
633	1250	—	—	633	1250
659	1300	—	—	659	1300
709	1400	—	—	709	1400
760	1500	—	—	760	1500
811	1600	—	—	811	1600

Table 4 Continued on Next Page

Table 4 Continued

Size of conductor		Nominal diameter of solid conductor		Nominal cross-sectional area of conductor	
mm <sup>2</sup>	AWG or kcmil	mm	mils	mm <sup>2</sup>	cmil or kcmil
861	1700	—	—	861	1700
887	1750	—	—	887	1750
912	1800	—	—	912	1800
963	1900	—	—	963	1900
1010	2000	—	—	963	1900

Table 5  
Diameters over Round Compact-Stranded Conductors  
(See Clause 4.1.6.1.)

Conductor size		Nominal diameter	
mm <sup>2</sup>	AWG or kcmil	mm	inch
3.31	12	2.16	0.085
5.26	10	2.72	0.107
8.37	8	3.40	0.134
13.3	6	4.29	0.169
21.2	4	5.41	0.213
26.7	3	6.02	0.238
33.6	2	6.81	0.268
42.4	1	7.59	0.299
53.5	1/0	8.53	0.336
67.4	2/0	9.55	0.376
85.0	3/0	10.74	0.423
107	4/0	12.07	0.475
127	250 kcmil	13.21	0.520
152	300	14.48	0.570
177	350	15.65	0.616
203	400	16.74	0.659
228	450	17.78	0.700
253	500	18.69	0.736
279	550	19.69	0.775
304	600	20.65	0.813
329	650	21.46	0.845
355	700	22.28	0.877
380	750	23.06	0.908
405	800	23.83	0.938
456	900	25.37	0.999
507	1000	26.92	1.060

**Table 6**  
**Diameters over Round Compressed Concentric-Lay-Stranded Conductors for**  
**Classes B, C, and D**  
**(See Clauses 4.1.6.1 and 4.1.6.2.)**

Conductor size		Nominal diameter	
mm <sup>2</sup>	AWG or kcmil	mm	inches
2.08	14 AWG	1.80	0.071
3.31	12	2.26	0.089
5.26	10	2.87	0.113
8.37	8	3.61	0.142
13.3	6	4.52	0.178
21.2	4	5.72	0.225
26.7	3	6.40	0.252
33.6	2	7.19	0.283
42.4	1	8.18	0.322
53.5	1/0	9.19	0.362
67.4	2/0	10.3	0.405
85.0	3/0	11.6	0.456
107	4/0	13.0	0.512
127	250 kcmil	14.2	0.558
152	300	15.5	0.611
177	350	16.8	0.661
203	400	17.9	0.706
226	450	19.0	0.749
253	500	20.0	0.789
279	550	21.1	0.829
304	600	22.0	0.866
329	650	22.9	0.901
355	700	23.7	0.935
380	750	24.6	0.968
405	800	25.4	1.000
456	900	26.9	1.060
507	1000	28.4	1.117
557	1100	29.8	1.173
608	1200	31.1	1.225
633	1250	31.8	1.250
659	1300	32.4	1.275
709	1400	33.6	1.323
760	1500	34.8	1.370
811	1600	35.9	1.415
861	1700	37.1	1.459
887	1750	37.6	1.480
912	1800	38.2	1.502
963	1900	39.2	1.542
1010	2000	40.2	1.583



**Table 7**  
**Diameters over Round Compressed Unidirectional or Unilay-Stranded Conductors for Class B**  
**(See Clause 4.1.6.1.)**

Conductor size		Nominal diameter	
mm <sup>2</sup>	AWG	mm	inches
42.4	1 AWG	7.95	0.313
53.5	1/0	8.94	0.352
67.4	2/0	10.03	0.395
85.0	3/0	11.25	0.443
107	4/0	12.65	0.498
127	250 kcmil	13.77	0.542
152	300	15.09	0.594
177	350	16.28	0.641
203	400	17.40	0.685
226	450	18.47	0.727
253	500	19.46	0.766
279	550	20.42	0.804
304	600	21.34	0.840
329	650	22.20	0.874
355	700	23.04	0.907
380	750	23.85	0.939
405	800	24.61	0.969
456	900	26.11	1.028
507	1000	27.53	1.084
557	1100	28.88	1.137
608	1200	30.15	1.187
633	1250	30.78	1.212
659	1300	31.39	1.236
709	1400	32.56	1.282
760	1500	33.71	1.327
811	1600	34.82	1.371
861	1700	35.89	1.413
887	1750	36.42	1.434
912	1800	33.71	1.327
963	1900	37.95	1.494
1010	2000	38.94	1.533

**Table 8**  
**Diameter over Round Concentric-Lay-Stranded**  
**Conductors for Classes B, C, and D**  
**(See Clause 4.1.6.1.)**

Conductor size		Nominal diameter	
mm <sup>2</sup>	AWG or kcmil	mm	inches
2.08	14 AWG	1.85	0.0727
3.31	12	2.32	0.0915
5.26	10	2.95	0.116
8.37	8	3.71	0.146
13.3	6	4.67	0.184
21.2	4	5.89	0.232
26.7	3	6.60	0.260
33.6	2	7.42	0.292
42.4	1	8.43	0.332
53.5	1/0	9.45	0.372
67.4	2/0	10.62	0.418
85.0	3/0	11.94	0.470
107	4/0	13.41	0.528
127	250 kcmil	14.6	0.575
152	300	16.00	0.630
177	350	17.30	0.681
203	400	18.49	0.728
228	450	19.61	0.772
253	500	20.65	0.813
279	550	21.72	0.855
304	600	22.68	0.893
329	650	23.60	0.929
355	700	24.49	0.964
380	750	25.35	0.998
405	800	26.16	1.030
456	900	27.79	1.094
507	1000	29.26	1.152
557	1100	30.71	1.209
608	1200	32.08	1.263
633	1250	32.74	1.289
659	1300	33.38	1.314
709	1400	34.67	1.365
760	1500	35.86	1.412
811	1600	37.06	1.459
861	1700	38.20	1.504

Table 8 Continued on Next Page

Table 8 Continued

Conductor size		Nominal diameter	
mm <sup>2</sup>	AWG or kcmil	mm	inches
887	1750	38.76	1.526
912	1800	39.32	1.548
963	1900	40.39	1.590
1010	2000	41.45	1.632

Table 9  
Strand and Conductor Dimensions for 19-Wire Combination  
Round-Wire Unilay-Stranded Conductors  
(See Clause 4.1.6.1.)

Conductor size		Nominal strand dimensions								Nominal conductor diameter E = 3A + 2C	
		Large strand				Small strand					
		Diameter (A)		Cross-sectional area		Diameter (C)		Cross-sectional area			
mm <sup>2</sup>	AWG	mm	inch	mm <sup>2</sup>	cmil	mm	inch	mm <sup>2</sup>	cmil	mm	inch
2.08	14	0.4	0.0159	0.128	253	0.3	0.0117	0.069	137	1.80	0.071
3.31	12	0.5	0.0210	0.223	441	0.4	0.0147	0.110	217	2.29	0.090
5.26	10	0.6	0.0253	0.324	640	0.5	0.0185	0.173	342	2.87	0.113
8.37	8	0.8	0.0319	0.515	1018	0.6	0.0234	0.277	548	3.63	0.143
13.3	6	1.0	0.0402	0.818	1616	0.7	0.0294	0.437	864	4.55	0.179
21.2	4	1.3	0.0507	1.301	2570	0.9	0.0371	0.696	1376	5.74	0.226
26.7	3	1.4	0.0570	1.644	3249	1.1	0.0417	0.880	1739	6.45	0.254
33.6	2	1.6	0.0640	2.073	4096	1.2	0.0468	1.108	2190	7.26	0.286
42.4	1	1.8	0.0718	2.609	5155	1.3	0.0526	1.400	2767	8.15	0.321
53.5	1/0	2.1	0.0807	3.296	6512	1.5	0.0591	1.768	3493	9.14	0.360
67.4	2/0	2.3	0.0906	4.154	8208	1.7	0.0663	2.225	4396	10.26	0.404
85.0	3/0	2.6	0.1017	5.234	10343	1.9	0.0745	2.809	5550	11.53	0.454
107	4/0	2.9	0.1142	6.600	13042	2.1	0.0836	3.537	6989	12.95	0.510

**Table 10**  
**Insulation Thickness,**  
**Average and Minimum at Any Point**  
**(See Clauses 4.2.4 and 7.2.2.)**

Conductor size		TWU, TWU75				THW, TW75, THW-2, THW-LS, THHW, THHW-LS, TW				THHN, T90 Nylon, THWN-2, THWN, TWN75			
		Average		Minimum		Average		Minimum		Average		Minimum	
mm <sup>2</sup>	AWG or kcmil	mm	mils	mm	mils	mm	mils	mm	mils	mm	mils	mm	mils
2.08 – 3.31	14 – 12	1.52	60	1.37	54	0.76	30	0.69	27	0.38	15	0.33	13
5.26	10	1.52	60	1.37	54	0.76	30	0.69	27	0.51	20	0.46	18
8.37	8	2.03	80	1.83	72	1.14	45	1.02	40	0.76	30	0.69	27
13.3	6	2.03	80	1.83	72	1.52	60	1.37	54	0.76	30	0.69	27
21.2 – 33.6	4 – 2	2.03	80	1.83	72	1.52	60	1.37	54	1.02	40	0.91	36
42.4 – 107	1 – 4/0	2.41	95	2.18	86	2.03	80	1.83	72	1.27	50	1.14	45
127 – 253	250 – 500	2.79	110	2.51	99	2.41	95	2.18	86	1.52	60	1.38	54
279 – 507	550 – 1000	3.18	125	2.84	112	2.79	110	2.51	99	1.78	70	1.60	63
557 – 1010	1100 – 2000	3.55	155	3.20	139	3.18	125	2.84	112	–	–	–	–

**Table 11**  
**Physical Properties of PVC Insulation**  
**(See Clauses 4.2.5.1.1, 4.2.5.3.2, and 4.2.5.3.3.)**

Minimum properties	TW, TWU	TWU75	THW or TW75	THW-2	THW-LS	THHW, THHN, THWN-2, THHW-LS, T90 Nylon	THWN or TWN75
Before aging: Tensile strength, MPa (lbf/in <sup>2</sup> )	10.3 (1500)	12.4 (1800)		13.8 (2000)			
Elongation, percent, minimum increase in distance between 25 mm (1 inch) gauge marks	100	150					
After aging: at 100°C, 7d							
Retention of tensile strength, percent	Min. 65	–					
Retention of elongation, percent	65/45 <sup>a</sup>	–					
After aging: at 121°C, 7d							
Retention of tensile strength, percent	–	75	–	75	–	75	
Retention of elongation, percent	–	65/45 <sup>a</sup>	–	65/45 <sup>a</sup>	–	65/45 <sup>a</sup>	
After aging: at 136°C, 7d							
Retention of tensile strength, percent	–	75		–	75	–	
Retention of elongation, percent	–	65/45 <sup>a</sup>		–	65/45 <sup>a</sup>	–	

Table 11 Continued on Next Page

**Table 11 Continued**

Minimum properties	TW, TWU	TWU75	THW or TW75	THW-2	THW-LS	THHW, THHN, THWN-2, THHW-LS, T90 Nylon	THWN or TWN75
<sup>a</sup> The 45 percent applies only to samples aged in die-cut form.							

**Table 12**  
**Worksheet for Determination of Physical Properties of Insulation Having Characteristics Different from Those Indicated in Table 11<sup>a</sup>**  
**(See Clause 4.2.5.3.4.)**

Condition of specimens at time of measurement	Minimum ultimate elongation (25 mm (1 inch) benchmarks)	Minimum tensile strength
Unaged	b	b
Insulation from wires rated 90°C (covering, if present, removed before aging): Aged in a full-draft circulating-air oven for 168 h at 136 ± 1° C	b	b
Insulation from wires rated 75°C (covering, if present, removed before aging): Aged in a full-draft circulating-air oven for 168 h at 121 ± 1° C	b	b
Insulation from wires rated 60°C (covering, if present, removed before aging): Aged in a full-draft circulating-air oven for 168 h at 100 ± 1° C	b	b

<sup>a</sup> See Clause 4.2.5.3.2, which establishes that the initial values of tensile strength and elongation shall be at least 6.8 MPa (1000 lbf/in<sup>2</sup>) and 100 percent, respectively.

<sup>b</sup> Values as determined in accordance with Annex D of UL 2556, CSA C22.2 No. 2556, or NMX-J-178-ANCE.

**Table 13**  
**Thickness of Jacket over Types THHN, THWN, TWN75, THWN-2, and T90 Nylon**  
**(See Clause 4.3.2.)**

Conductor size (AWG or kcmil)		Minimum thickness at any point	
mm <sup>2</sup>	AWG or kcmil	mm	mils
2.08 – 5.26	14 – 10	0.10	4
8.37 – 13.3	8 – 6	0.13	5
21.2 – 33.6	4 – 2	0.15	6
42.4 – 107	1 – 4/0	0.18	7
127 – 253	250 – 500	0.20	8
279 – 507	550 – 1000	0.23	9

**Table 14**  
**Maximum Direct-Current Resistance at 20°C of Solid Conductors of Aluminum and Bare Copper**  
**(See Clauses 5.2 and E3.)**

Size of conductor		Aluminum		Bare copper	
mm <sup>2</sup>	AWG	Ohms per km	Ohms per 1000 ft	Ohms per km	Ohms per 1000 ft
2.08	14	—	—	8.45	2.57
3.31	12	8.71	2.65	5.31	1.62
5.26	10	5.48	1.67	3.34	1.02
8.37	8	3.45	1.05	2.10	0.641
13.3	6	2.17	0.661	1.32	0.403
21.2	4	1.36	0.416	0.832	0.254
26.7	3	1.08	0.330	0.660	0.201
33.6	2	0.857	0.261	0.523	0.159
42.4	1	0.680	0.207	0.415	0.126
53.5	1/0	0.539	0.164	0.329	0.100
67.4	2/0	0.428	0.130	0.261	0.0795
85.0	3/0	0.339	0.103	0.207	0.0631
107	4/0	0.269	0.0820	0.16	0.0500

**Table 15**  
**Maximum Direct-Current Resistance at 20°C of Aluminum and Bare Copper Conductors –**  
**Concentric-Stranded Classes B, C, and D; Compact-Stranded; and Compressed-Stranded**  
**(See Clauses 5.2 and E3.)**

Size of conductor		Aluminum		Bare copper	
mm <sup>2</sup>	AWG or kcmil	Ohms per km	Ohms per 1000 ft	Ohms per km	Ohms per 1000 ft
2.08	14 AWG	—	—	8.62	2.62
3.31	12	8.88	2.71	5.43	1.65
5.26	10	5.59	1.70	3.41	1.04
8.37	8	3.52	1.07	2.14	0.653
13.3	6	2.21	0.674	1.35	0.411
21.2	4	1.39	0.424	0.848	0.259
26.7	3	1.10	0.336	0.673	0.205
33.6	2	0.875	0.267	0.534	0.163
42.4	1	0.693	0.211	0.423	0.130
53.5	1/0	0.550	0.168	0.335	0.102
67.4	2/0	0.436	0.133	0.266	0.0811
85.0	3/0	0.346	0.106	0.211	0.0643
107	4/0	0.274	0.0836	0.167	0.0510
127	250 kcmil	0.232	0.0708	0.142	0.0432
152	300	0.194	0.0590	0.118	0.0360
177	350	0.166	0.0505	0.101	0.0308
203	400	0.145	0.0442	0.0885	0.0270
228	450	0.129	0.0393	0.0787	0.0240
253	500	0.116	0.0354	0.0709	0.0216

Table 15 Continued on Next Page

**Table 15 Continued**

Size of conductor		Aluminum		Bare copper	
mm <sup>2</sup>	AWG or kcmil	Ohms per km	Ohms per 1000 ft	Ohms per km	Ohms per 1000 ft
279	550	0.106	0.0322	0.0644	0.0196
304	600	0.0967	0.0295	0.0590	0.0180
329	650	0.0893	0.0272	0.0545	0.0166
355	700	0.0829	0.0253	0.0506	0.0154
380	750	0.0774	0.0236	0.0472	0.0144
405	800	0.0725	0.0221	0.0443	0.0135
456	900	0.0645	0.0197	0.0393	0.0120
507	1000	0.0580	0.0177	0.0354	0.0108
557	1100	0.0528	0.0161	0.0322	0.00981
608	1200	0.0484	0.0147	0.0295	0.00899
633	1250	0.0464	0.0142	0.0283	0.00863
659	1300	0.0447	0.0136	0.0272	0.00823
709	1400	0.0415	0.0126	0.0253	0.00771
760	1500	0.0387	0.0118	0.0236	0.00719
811	1600	0.0363	0.0111	0.0221	0.00674
861	1700	0.0341	0.0104	0.0208	0.00635
887	1750	0.0332	0.0101	0.0202	0.00617
912	1800	0.0322	0.00983	0.0197	0.00600
963	1900	0.0306	0.00931	0.0186	0.00568
1010	2000	0.0290	0.00884	0.0177	0.00540

**Note:** Nominal strand configuration and number of wires are found in ASTM B 8 or NMX-J-012-ANCE for copper conductors, and ASTM B 231 or NMX-J-032-ANCE for aluminum conductors.

**Table 16**  
**Maximum Direct-Current Resistance at 20°C of Copper Conductors, Concentric-Stranded Class B with Each Strand Coated with Tin or a Tin Alloy and Compressed-Stranded Class B with Each Strand Coated**  
**(See Clause 5.2.)**

Size of conductor		Ohms per km	Ohms per 1000 ft
mm <sup>2</sup>	AWG or kcmil		
2.08	14 AWG	8.96	2.73
3.31	12	5.64	1.72
5.26	10	3.55	1.08
8.37	8	2.23	0.680
13.3	6	1.40	0.428
21.2	4	0.882	0.269
26.7	3	0.700	0.213
33.6	2	0.555	0.169
42.4	1	0.440	0.134
53.5	1/0	0.349	0.106

Table 16 Continued on Next Page

Table 16 Continued

Size of conductor		Ohms per km	Ohms per 1000 ft
mm <sup>2</sup>	AWG or kcmil		
67.4	2/0	0.277	0.0843
85.0	3/0	0.219	0.0669
107	4/0	0.172	0.0525
127	250 kcmil	0.147	0.0449
152	300	0.123	0.0374
177	350	0.105	0.0320
203	400	0.0911	0.0278
228	450	0.0810	0.0247
253	500	0.0729	0.0222
279	550	0.0669	0.0204
304	600	0.0614	0.0187
329	650	0.0561	0.0171
355	700	0.0520	0.0159
380	750	0.0486	0.0148
405	800	0.0455	0.0139
456	900	0.0405	0.0123
507	1000	0.0364	0.0111
557	1100	0.0331	0.0101
608	1200	0.0303	0.00925
633	1250	0.0292	0.00888
659	1300	0.0280	0.00854
709	1400	0.0260	0.00793
760	1500	0.0243	0.00740
811	1600	0.0228	0.00694
861	1700	0.0214	0.00653
887	1750	0.0208	0.00635
912	1800	0.0202	0.00617
963	1900	0.0192	0.00584
1010	2000	0.0182	0.00555

**Note:** Nominal strand configuration and number of wires are found in ASTM B 8 or NMX-J-012-ANCE.



**Table 17**  
**Maximum Direct-Current Resistance at 20°C of Copper Conductors Concentric-Stranded Classes C and D with Each Strand Coated with Tin or a Tin Alloy and Compressed-Stranded Classes C and D with Each Strand Coated**  
**(See Clause 5.2.)**

Size of conductor		Class C		Class D	
mm <sup>2</sup>	AWG or kcmil	Ohms per km	Ohms per 1000 ft	Ohms per km	Ohms per 1000 ft
2.08	14 AWG	9.15	2.78	9.25	2.82
3.31	12	5.75	1.75	5.75	1.75
5.26	10	3.55	1.08	3.62	1.10
8.37	8	2.23	0.679	2.23	0.679
13.3	6	1.41	0.427	1.41	0.427
21.2	4	0.882	0.269	0.882	0.269
26.7	3	0.700	0.213	0.700	0.213
33.6	2	0.555	0.169	0.555	0.169
42.4	1	0.440	0.134	0.440	0.134
53.5	1/0	0.349	0.106	0.349	0.106
67.4	2/0	0.276	0.0844	0.276	0.0844
85.0	3/0	0.219	0.0669	0.219	0.0669
107	4/0	0.174	0.0530	0.174	0.0530
127	250 kcmil	0.147	0.0449	0.147	0.0449
152	300	0.122	0.0374	0.122	0.0374
177	350	0.105	0.0320	0.105	0.0320
203	400	0.0920	0.0280	0.0920	0.0280
228	450	0.0818	0.0249	0.0818	0.0249
253	500	0.0736	0.0224	0.0736	0.0224
279	550	0.0669	0.0204	0.0669	0.0204
304	600	0.0614	0.0187	0.0614	0.0187
329	650	0.0566	0.0172	0.0566	0.0172
355	700	0.0526	0.0160	0.0526	0.0160
380	750	0.0491	0.0150	0.0491	0.0150
405	800	0.0460	0.0141	0.0460	0.0141
456	900	0.0409	0.0124	0.0409	0.0124
507	1000	0.0364	0.0111	0.0368	0.0112
557	1100	0.0335	0.0102	0.0335	0.0102
608	1200	0.0307	0.00935	0.0307	0.00935
633	1250	0.0295	0.00898	0.0295	0.00898
659	1300	0.0284	0.00863	0.0284	0.00863
709	1400	0.0260	0.00794	0.0263	0.00802
760	1500	0.0243	0.00741	0.0246	0.00748
811	1600	0.0231	0.00702	0.0231	0.00702
861	1700	0.0216	0.00660	0.0216	0.00660
887	1750	0.0210	0.00642	0.0210	0.00642
912	1800	0.0202	0.00617	0.0205	0.00623
963	1900	0.0192	0.00584	0.0194	0.00591
1010	2000	0.0183	0.00555	0.0184	0.00561

**Note:** Nominal strand configuration and number of wires are found in ASTM B 8 or NMX-J-012-ANCE.

**Table 18**  
**Maximum Direct-Current Resistance at 20°C of 19-Wire Combination Round-Wire Unilay-Stranded**  
**Copper Conductors**  
**(See Clause 5.2.)**

Size of conductor		Each strand coated		Each strand uncoated	
mm <sup>2</sup>	AWG	Ohms per km	Ohms per 1000 ft	Ohms per km	Ohms per 1000 ft
2.08	14	9.15	2.78	8.62	2.62
3.31	12	5.75	1.75	5.43	1.65
5.26	10	3.55	1.08	3.41	1.04
8.37	8	2.23	0.679	2.14	0.654
13.3	6	1.41	0.427	1.35	0.412
21.2	4	0.882	0.269	0.848	0.259
26.7	3	0.700	0.213	0.673	0.205
33.6	2	0.555	0.169	0.534	0.163
42.4	1	0.440	0.134	0.423	0.129
53.5	1/0	0.349	0.106	0.335	0.102
67.4	2/0	0.277	0.0844	0.266	0.0811
85.0	3/0	0.219	0.0669	0.211	0.0643
107	4/0	0.172	0.05230	0.167	0.0510

**Table 19**  
**Maximum Direct-Current Resistance at 20°C of 19-Wire Combination Round-Wire Unilay-Stranded**  
**Aluminum Conductors**  
**(See Clause 5.2.)**

Size of conductor		Ohms per km	Ohms per 1000 ft
mm <sup>2</sup>	AWG		
13.3	6	2.21	0.674
21.2	4	1.39	0.424
26.7	3	1.10	0.336
33.6	2	0.875	0.267
42.4	1	0.693	0.211
53.5	1/0	0.550	0.168
67.4	2/0	0.436	0.133
85.0	3/0	0.346	0.106
107	4/0	0.274	0.0836

**Table 20**  
**Maximum Direct-Current Resistance at 20°C of Solid Copper Conductors Coated with Tin or a Tin Alloy**  
**(See Clause 5.2.)**

Conductor size		Ohms per km	Ohms per 1000 ft
mm <sup>2</sup>	AWG		
2.08	14	8.78	2.68
3.31	12	5.53	1.68
5.26	10	3.48	1.06
8.37	8	2.16	0.659
13.3	6	1.36	0.415
21.2	4	0.856	0.261
26.7	3	0.679	0.207
33.6	2	0.538	0.164
42.4	1	0.427	0.130
53.5	1/0	0.337	0.103
67.4	2/0	0.267	0.0814
85.0	3/0	0.212	0.0655
107	4/0	0.168	0.0512

**Table 21**  
**Maximum Direct-Current Resistance at 20°C of Class G Stranded Conductors**  
**(See Clause 5.2.)**

Size of conductor		Bare copper		Coated copper (each strand coated with tin or a tin alloy)		Aluminum	
mm <sup>2</sup>	AWG or kcmil	Ohms per km	Ohms per 1000 ft	Ohms per km	Ohms per 1000 ft	Ohms per km	Ohms per 1000 ft
2.08	14 AWG	8.70	2.65	9.24	2.82	—	—
3.31	12	5.48	1.67	5.81	1.77	—	—
5.26	10	3.45	1.05	3.66	1.11	—	—
8.37	8	2.16	0.660	2.30	0.701	—	—
13.3	6	1.37	0.415	1.42	0.431	2.23	0.680
21.2	4	0.857	0.261	0.890	0.271	1.41	0.428
26.7	3	0.679	0.207	0.707	0.215	1.11	0.340
33.6	2	0.539	0.164	0.560	0.170	0.883	0.369
42.4	1	0.431	0.132	0.449	0.137	0.707	0.215
53.5	1/0	0.342	0.104	0.355	0.108	0.560	0.170
67.4	2/0	0.271	0.0826	0.282	0.0860	0.445	0.136
85.0	3/0	0.215	0.0656	0.223	0.0681	0.353	0.107
107	4/0	0.170	0.0520	0.177	0.0541	0.279	0.0853
127	250 kcmil	0.145	0.0443	0.151	0.0460	0.238	0.0725
152	300	0.121	0.0368	0.125	0.0384	0.198	0.0604
177	350	0.104	0.0316	0.108	0.0328	0.170	0.0518
203	400	0.0917					

Table 21 Continued on Next Page

Table 21 Continued

Size of conductor		Bare copper		Coated copper (each strand coated with tin or a tin alloy)		Aluminum	
mm <sup>2</sup>	AWG or kcmil	Ohms per km	Ohms per 1000 ft	Ohms per km	Ohms per 1000 ft	Ohms per km	Ohms per 1000 ft
226	450	0.0806	0.0246	0.0838	0.0255	0.132	0.0403
253	500	0.0725	0.0221	0.0755	0.0230	0.119	0.0362
279	550	0.0663	0.0202	0.0690	0.0210	0.108	0.0332
304	600	0.0607	0.0186	0.0631	0.0193	0.0996	0.0304
329	650	0.0561	0.0171	0.0583	0.0177	0.0919	0.0280
355	700	0.0520	0.0159	0.0542	0.0165	0.0834	0.0260
380	750	0.0486	0.0148	0.0505	0.0154	0.0797	0.0243
405	800	0.0456	0.0139	0.0473	0.0145	0.0747	0.0227
456	900	0.0405	0.0123	0.0421	0.0129	0.0664	0.0202
507	1000	0.0364	0.0111	0.0379	0.0115	0.0598	0.0183
557	1100	0.0332	0.0101	0.0345	0.0105	0.0543	0.0165
608	1200	0.0304	0.00926	0.0316	0.00963	0.0498	0.0152
633	1250	0.0292	0.00888	0.0303	0.00924	0.0478	0.0146
659	1300	0.0280	0.00855	0.0292	0.00888	0.0460	0.0140
709	1400	0.0260	0.00794	0.0270	0.00825	0.0426	0.0131
760	1500	0.0243	0.00741	0.0253	0.00770	0.0398	0.0121
811	1600	0.0230	0.00701	0.0239	0.00729	0.0377	0.0115
861	1700	0.0216	0.00660	0.0225	0.00686	0.0355	0.0108
887	1750	0.0210	0.00641	0.0218	0.00666	0.0345	0.0105
912	1800	0.0204	0.00623	0.0212	0.00648	0.0335	0.0102
963	1900	0.0194	0.00591	0.0201	0.00614	0.0317	0.00968
1010	2000	0.0184	0.00561	0.0192	0.00583	0.0302	0.00919

**Note:** Nominal strand configuration and number of wires are found in ASTM B 173 or NMX-J-013-ANCE.

**Table 22**  
**Maximum Direct-Current Resistance at 20°C of Class M Stranded Conductors**  
**(See Clause 5.2.)**

Size of conductor		Bare copper		Coated copper (each strand coated with tin or a tin alloy)	
mm <sup>2</sup>	AWG or kcmil	Ohms per km	Ohms per 1000 ft	Ohms per km	Ohms per 1000 ft
2.08	14 AWG	8.61	2.62	9.25	2.82
3.31	12	5.53	1.68	5.94	1.81
5.26	10	3.48	1.06	3.73	1.14
8.37	8	2.18	0.666	2.35	0.715
13.3	6	1.39	0.423	1.49	0.455
21.2	4	0.873	0.266	0.937	0.286
26.7	3	0.699	0.213	0.744	0.226
33.6	2	0.554	0.169	0.595	0.182
42.4	1	0.440	0.134	0.472	0.144
53.5	1/0	0.349	0.106	0.374	0.114
67.4	2/0	0.276	0.0851	0.300	0.0913
85.0	3/0	0.221	0.0874	0.238	0.0724
107	4/0	0.175	0.0534	0.189	0.0574
127	250 kcmil	0.149	0.0453	0.159	0.0487
152	300	0.123	0.0377	0.133	0.0405
177	350	0.106	0.0323	0.114	0.0347
203	400	0.0928	0.0283	0.0997	0.0304
226	450	0.0825	0.0252	0.0858	0.0261
253	500	0.0743	0.0226	0.0798	0.0243
279	550	0.0675	0.0206	0.0725	0.0221
304	600	0.0619	0.0189	0.0664	0.0203
329	650	0.0571	0.0174	0.0613	0.0187
355	700	0.0530	0.0162	0.0569	0.0173
380	750	0.0495	0.0151	0.0531	0.0162
405	800	0.0464	0.0142	0.0499	0.0152
456	900	0.0413	0.0125	0.0443	0.0135
507	1000	0.0371	0.0113	0.0399	0.0121

**Note:** Nominal strand configuration and number of wires are found in ASTM B 172 or NMX-J-014-ANCE.

**Table 23**  
**Minimum Insulation Resistance at Elevated Temperature in Water**  
**(See Clauses 5.4, 5.5.1.1, and 5.5.2.)**

Conductor size		GΩ·m					MΩ·1000 ft				
mm <sup>2</sup>	AWG or kcmil	50 or 60°C test		75 or 90°C test			50 or 60°C test		75 or 90°C test		
		TW	TWU	TWU75 (75°C test)	THW <sup>a</sup> , THW-LS, THHW, THHW-LS or TW75 (75°C test), THW-2 (90°C test)	Type THWN or TWN75 (75°C test), THWN-2 (90°C test)	TW	TWU	TWU75 (75°C test)	THW <sup>a</sup> , THW-LS, THHW, THHW-LS or TW75 (75°C test), THW-2 (90°C test)	Type THWN or TWN75 (75°C test), THWN-2 (90°C test)
2.08	14 AWG	0.030	0.042	0.042	0.120	0.035	0.095	0.138	0.138	0.380	0.115
3.31	12	0.025	0.036	0.036	0.100	0.030	0.080	0.118	0.118	0.320	0.095
5.26	10	0.025	0.030	0.030	0.085	0.035	0.065	0.098	0.098	0.265	0.100
8.37	8	0.025	0.032	0.032	0.085	0.035	0.070	0.105	0.105	0.270	0.100
13.3	6	0.025	0.027	0.027	0.090	0.030	0.070	0.089	0.089	0.285	0.085
21.2	4	0.020	0.022	0.022	0.075	0.030	0.060	0.072	0.072	0.240	0.085
26.7	3	0.020	0.020	0.020	0.070	0.025	0.050	0.066	0.066	0.215	0.080
33.6	2	0.015	0.0185	0.0185	0.060	0.025	0.050	0.061	0.061	0.195	0.070
42.4	1	0.020	0.0195	0.0195	0.070	0.025	0.055	0.064	0.064	0.225	0.075
53.5	1/0	0.020	0.0175	0.0175	0.065	0.025	0.050	0.057	0.057	0.205	0.070
67.4	2/0	0.015	0.0160	0.0160	0.060	0.020	0.045	0.052	0.052	0.185	0.065
85.0	3/0	0.015	0.0145	0.0145	0.055	0.020	0.040	0.048	0.048	0.165	0.055
107	4/0	0.015	0.0130	0.0130	0.050	0.020	0.035	0.043	0.043	0.150	0.050
127	250 kcmil	0.015	0.0140	0.0140	0.050	0.020	0.040	0.046	0.046	0.160	0.055
152	300	0.015	0.0130	0.0130	0.050	0.020	0.035	0.043	0.043	0.150	0.050
177	350	0.015	0.0120	0.0120	0.045	0.015	0.035	0.039	0.039	0.140	0.050
203	400	0.010	0.0110	0.0110	0.040	0.015	0.030	0.036	0.036	0.130	0.045
226	450	0.010	0.0105	0.0105	0.040	0.015	0.030	0.034	0.034	0.125	0.045
253	500	0.010	0.00100	0.0100	0.040	0.015	0.030	0.033	0.033	0.115	0.040
279	550	0.010	–	–	0.040	0.015	0.030	–	–	0.130	0.045
304	600	0.010	0.0105	0.0105	0.040	0.015	0.030	0.034	0.034	0.125	0.045
329	650	0.010	–	–	0.040	0.015	0.030	–	–	0.120	0.040
355	700	0.010	0.0100	0.0100	0.040	0.015	0.030	0.033	0.033	0.115	0.040
380	750	0.010	0.0097	0.0097	0.035	0.015	0.025	0.032	0.032	0.115	0.040
405	800	0.010	0.0094	0.0094	0.035	0.015	0.025	0.031	0.031	0.110	0.040
456	900	0.010	0.0089	0.0089	0.035	0.010	0.025	0.029	0.029	0.105	0.035
507	1000	0.010	0.0085	0.0085	0.030	0.010	0.025	0.028	0.028	0.100	0.030
557	1100	0.010	–	–	0.030	–	0.020	–	–	0.095	–
608	1200	0.010	–	–	0.030	–	0.020	–	–	0.090	–
633	1250	0.010	0.0085	0.0085	0.030	–	0.020	0.028	0.028	0.090	–
659	1300	0.010	–	–	0.030	–	0.020	–	–	0.090	–

Table 23 Continued on Next Page

Table 23 Continued

Conductor size		GΩ·m					MΩ·1000 ft				
mm <sup>2</sup>	AWG or kcmil	50 or 60°C test		75 or 90°C test			50 or 60°C test		75 or 90°C test		
		TW	TWU	TWU75 (75°C test)	THW <sup>a</sup> , THW-LS, THHW, THHW-LS or TW75 (75°C test), THW-2 (90°C test)	Type THWN or TWN75 (75°C test), THWN-2 (90°C test)	TW	TWU	TWU75 (75°C test)	THW <sup>a</sup> , THW-LS, THHW, THHW-LS or TW75 (75°C test), THW-2 (90°C test)	Type THWN or TWN75 (75°C test), THWN-2 (90°C test)
709	1400	0.010	—	—	0.030	—	0.020	—	—	0.085	—
760	1500	0.010	0.0078	0.0078	0.030	—	0.020	0.026	0.026	0.085	—
811	1600	0.010	—	—	0.025	—	0.020	—	—	0.080	—
861	1700	0.010	—	—	0.025	—	0.020	—	—	0.080	—
887	1750	0.010	0.0073	0.0073	0.025	—	0.015	0.024	0.024	0.075	—
912	1800	0.010	—	—	0.025	—	0.015	—	—	0.075	—
963	1900	0.010	—	—	0.025	—	0.015	—	—	0.075	—
1010	2000	0.005	0.0068	0.0068	0.025	—	0.015	0.022	0.022	0.070	—

<sup>a</sup> The values in this column apply to Type THW or THW-2 wire with a single or double layer of insulation.

Table 24  
 Minimum Acceptable Long-Term Insulation Resistance  
 in Air of Types THHN and T90 at 97.0°C (206.6°F)  
 (See Clause 5.6.3.)

Size of conductor		GΩ·m	MΩ·1000 ft
mm <sup>2</sup>	AWG or kcmil		
2.08	14 AWG	0.080	0.260
3.31	12	0.070	0.220
5.26	10	0.070	0.230
8.37	8	0.075	0.235
13.3	6	0.060	
21.2	4	0.065	0.200
26.7	3	0.060	0.185
33.6	2	0.050	0.160
42.4	1	0.055	0.180
53.5	1/0	0.050	0.160
67.4	2/0	0.045	0.145
85.0	3/0	0.040	0.130
107	4/0	0.040	0.115
127	250 kcmil	0.040	0.130
152	300	0.040	0.115
177	350	0.035	0.110
203	400	0.035	0.100
226	450	0.035	0.100
253	500	0.030	0.095

Table 24 Continued on Next Page

Table 24 Continued

Size of conductor		GΩ·m	MΩ·1000 ft
mm <sup>2</sup>	AWG or kcmil		
279	550	0.035	0.100
304	600	0.035	0.100
329	650	0.030	0.095
355	700	0.030	0.090
380	750	0.030	0.090
405	800	0.030	0.090
456	900	0.030	0.080
507	1000	0.025	0.075

Table 25  
Mandrel Diameters<sup>a</sup>  
(See Clauses 5.9 and 5.10.1.)

Size of conductor		A (Heat shock)		B (Room temperature and cold bend)	
mm <sup>2</sup>	AWG	mm	inches	mm	inches
2.08	14	3	0.133	8	0.313
3.31	12	4	0.148	9	0.375
5.26	10	4	0.168	14	0.563
8.37	8	6	0.228	17	0.688
13.3	6	16	0.646	32	1.250
21.2	4	19	0.744	35	1.375
26.7	3	20	0.802	37	1.458
33.6	2	22	0.866	40	1.563
42.4	1	26	1.016	68	2.688
53.5	1/0	28	1.098	73	2.875
67.4	2/0	30	1.190	76	3.000
85.0	3/0	33	1.294	83	3.250
107	4/0	36	1.410	89	3.500
127	250 kcmil	100	3.940	160	6.304
152	300	107	4.215	171	6.744
177	350	114	4.475	182	7.160
203	400	120	4.710	191	7.536
228	450	125	4.935	201	7.904
253	500	131	5.145	209	8.232
279	550	140	5.515	280	11.030
304	600	145	5.715	290	11.430
329	650	150	5.895	299	11.790
355	700	154	6.070	308	12.140
380	750	159	6.245	317	12.490
405	800	163	6.410	326	12.820
456	900	171	6.725	342	13.450

Table 25 Continued on Next Page



Table 25 Continued

Size of conductor		A (Heat shock)		B (Room temperature and cold bend)	
mm <sup>2</sup>	AWG	mm	inches	mm	inches
507	1000	178	7.020	357	14.040
608	1200	197	7.745	393	15.490
633	1250	200	7.885	401	15.770
659	1300	204	8.025	408	16.050
709	1400	210	8.270	420	16.540
760	1500	216	8.510	432	17.020
811	1600	222	8.745	444	17.490
861	1700	228	8.970	456	17.940
887	1750	231	9.085	462	18.170
912	1800	233	9.190	267	18.380
963	1900	239	9.400	478	18.800
1010	2000	244	9.610	488	19.220

<sup>a</sup> When the mandrel specified is not available, it shall be permitted to use a mandrel with a smaller diameter. However, in the case of noncompliant result, the wire or cable shall be re-tested using the specified mandrel.

**Table 26**  
**Deformation Load Requirements**  
**(See Clause 5.11.)**

Size of conductor		Load <sup>a</sup> exerted on a specimen by the foot of the rod	
mm <sup>2</sup>	AWG or kcmil	N	gf
2.08 – 8.37	14 – 8	4.90	500
13.3 – 42.4	6 – 1	7.35	750
53.5 – 107	1/0 – 4/0	9.81	1000
127 – 1010	250 – 2000	19.61	2000

<sup>a</sup> The specified load is not the weight to be added to each rod in the test apparatus but rather the total of the weight added and the weight of the rod. Because the weight of the rod varies from one apparatus to another, specifying the exact weight to be added to a rod to achieve the specified load on a specimen in all cases is impractical except for an individual apparatus.

**Table 27**  
**Minimum Insulation Resistance at 15°C in Water**  
**(See Clause 5.24.)**

Conductor size		GΩ·m				MΩ·1000 ft			
mm <sup>2</sup>	AWG or kcmil	Type TW, TW75	Types TWU, TWU75	Types THW-2, THHW, THHW-LS, THW, TWN75, and THW-LS	Types THWN-2, THWN, THHN, and T90 Nylon	Type TW, TW75	Types TWU, TWU75	Types THW-2, THHW, THHW-LS, THW, TWN75, and THW-LS	Types THWN-2, THWN, THHN, and T90 Nylon
2.08	14 AWG	45	65	175	205	140	205	570	655
3.31	12	40	55	150	175	120	175	485	560
5.26	10	35	45	125	180	100	150	405	580
8.37	8	35	50	130	185	105	155	415	595
13.3	6	35	40	135	155	105	130	435	495
21.2	4	30	35	115	155	90	110	360	505
26.7	3	25	30	110	145	80	100	325	465
33.6	2	25	30	95	130	75	90	295	415
42.4	1	30	30	105	140	85	95	340	455
53.5	1/0	25	25	95	130	75	85	310	415
67.4	2/0	25	25	85	115	70	80	280	370
85.0	3/0	20	20	80	105	60	70	250	330
107	4/0	20	20	70	95	55	65	225	300
127	250 kcmil	20	20	80	105	60	70	245	330
152	300	20	20	70	95	55	65	225	300
177	350	20	20	65	90	50	60	210	285
203	400	15	15	65	80	50	55	200	255
226	450	15	15	60	80	45	50	190	255
253	500	15	15	55	75	45	50	180	240
279	550	15	–	65	80	50	–	200	255
304	600	15	15	60	80	45	50	190	255
329	650	15	–	60	75	45	–	185	240
355	700	15	15	55	70	45	50	180	225
380	750	15	–	55	70	40	–	170	225
405	800	15	15	55	70	40	45	165	225
456	900	15	15	50	65	40	45	155	210
507	1000	15	15	50	60	35	40	150	195
557	1100	15	–	45	–	35	–	140	–
608	1200	10	–	45	–	30	–	135	–
633	1250	10	15	45	–	30	40	135	–
659	1300	10	–	45	–	30	–	135	–
709	1400	10	–	40	–	30	–	125	–
760	1500	10	10	40	–	30	40	125	–
811	1600	10	–	40	–	30	–	120	–

Table 27 Continued on Next Page

Table 27 Continued

Conductor size		GΩ·m				MΩ·1000 ft			
mm <sup>2</sup>	AWG or kcmil	Type TW, TW75	Types TWU, TWU75	Types THW-2, THHW, THHW-LS, THW, TWN75, and THW-LS	Types THWN-2, THWN, THHN, and T90 Nylon	Type TW, TW75	Types TWU, TWU75	Types THW-2, THHW, THHW-LS, THW, TWN75, and THW-LS	Types THWN-2, THWN, THHN, and T90 Nylon
861	1700	10	–	40	–	30	–	120	–
887	1750	10	10	35	–	25	35	110	–
912	1800	10	–	35	–	25	–	110	–
963	1900	10	–	35	–	25	–	110	–
1010	2000	10	10	35	–	25	35	105	–

**Note:** The K values at 15°C (60°F) are

a) for Type TW: 500;

b) for Type THW: 2000;

c) for Type THWN: 4000.

**Table 28**  
**Smallest Acceptable Size of Optional Equipment Grounding Conductors in Deep-Well Submersible Water Pump Cables with Copper Circuit Conductors**  
 (See Clause 7.2.1.)

Size of copper circuit conductors		Smallest acceptable size of equipment grounding conductor, AWG or kcmil					
mm <sup>2</sup>	AWG or kcmil	Conductor temperature rating, °C					
		90		75		60	
		Copper	Aluminum	Copper	Aluminum	Copper	Aluminum
2.08	14	14	12	14	12	14	12
3.31	12	12	10	12	10	12	10
5.26	10	10	8	10	8	10	8
8.37	8	10	8	10	8	10	8
13.3	6	8	6	8	6	10	8
21.2	4	8	6	8	6	8	6
26.7	3	6	4	8	6	8	6
33.6	2	6	4	6	4	8	6
42.4	1	6	4	6	4	6	4
53.5	1/0	6	4	6	4	6	4
67.4	2/0	6	4	6	4	6	4
85.0	3/0	4	2	6	4	6	4
107	4/0	4	2	4	2	6	4
127	250	4	2	4	2	4	2
152	300	3	1	4	2	4	2
177	350	3	1	3	1	4	2
203	400	3	1	3	1	4	2
253	500	2	1/0	3	1	3	1

**Table 29**  
**Smallest Acceptable Size of Optional Equipment Grounding Conductors in Deep-Well**  
**Submersible Water Pump Cables with Aluminum Circuit Conductors**  
**(See Clause 7.2.1.)**

Size of aluminum circuit conductors		Smallest acceptable size of equipment grounding conductor, AWG or kcmil					
mm <sup>2</sup>	AWG or kcmil	Conductor temperature rating, °C					
		90		75		60	
		Aluminum	Copper	Aluminum	Copper	Aluminum	Copper
3.31	12	12	14	12	14	12	14
5.26	10	10	12	10	12	10	12
8.37	8	8	10	8	10	8	10
13.3	6	8	10	8	10	8	10
21.2	4	6	8	6	8	8	10
26.7	3	6	8	6	8	6	8
33.6	2	6	8	6	8	6	8
42.4	1	4	6	6	8	6	8
53.5	1/0	4	6	4	6	6	8
67.4	2/0	4	6	4	6	4	6
85.0	3/0	4	6	4	6	4	6
107	4/0	2	4	4	6	4	6
127	250	2	4	2	4	4	6
152	300	2	4	2	4	4	6
177	350	2	4	2	4	2	4
203	400	1	3	2	4	2	4
253	500	1	3	1	3	2	4

**Table 30**  
**Insulated Conductors Used in Deep-Well**  
**Submersible Water Pump Cable**  
**(See Clauses 7.2.2 and 7.2.3.)**

<b>Group I</b>	TW, THW, THW-2, THHW
<b>Group II</b>	THWN, THWN-2
<b>Group III</b>	TWU, TWU75
<b>Group IV</b>	Polyethylene insulated
<b>Note:</b> In Canada, Group III conductors are required by Section 26 of the Canadian Electrical Code.	

**Table 31**  
**Integral Jacket Thickness for Group I Deep-Well Submersible Water Pump Cables**  
 (See Clause 7.2.2 and 7.2.3.)

Conductor size		Jacket thickness			
mm <sup>2</sup>	AWG	Minimum average		Minimum at any point	
		mm	mils	mm	mils
2.08 – 8.37	14 – 8	0.38	15	0.31	12
13.3 and larger	6 and larger	0	0	0	0

**Table 32**  
**Polyethylene Insulation Thickness and Dielectric Withstand Voltage**  
**for Deep-Well Submersible Water Pump Cable**  
 (See Clauses 7.2.2, 7.4.1, and 7.4.2.)

Conductor size		Insulation thickness		Dielectric test voltage,	Spark test,
mm <sup>2</sup>	AWG or kcmil	Minimum average,	Minimum at any point,		
		mm (mils)	mm (mils)	KVAC	KVAC
2.08 – 5.26	14 – 10	1.14 (45)	1.02 (40)	5.5	10.0
8.37 – 33.6	8 – 2	1.40 (55)	1.26 (50)	7.0	12.0
53.5 – 107	1/0 – 4/0	1.65 (65)	1.50 (59)	8.0	15.0
127 253	250 – 500	2.03 (80)	1.83 (72)	9.5	20.0

**Table 33**  
**Properties of Polyethylene Insulation Used in**  
**Deep-Well Submersible Water Pump Cables**  
 (See Clauses 7.2.2 and 7.4.1.)

Properties	Value
<b>Before aging</b>	
Tensile strength, Mpa	Min. 9.6
Elongation, percent	Min. 350
<b>After air oven</b>	
Time/temperature	48 h/100°C
Retention of elongation, percent	Min. 75
Retention of tensile strength, percent	Min. 75
<b>Capacitance and relative permittivity</b>	
Test temperature, °C	75
Dielectric constant 24 h	Max. 6
1 d to 14 d	Max. 10 percent
7 d to 14 d	Max. 4 percent

**Table 34**  
**Thickness of Overall Jacket Other Than Polyethylene, for Deep-Well Submersible Water Pump Cables**  
**(See Clause 7.2.3.)**

Size of conductor	Jacket thickness			
	Minimum average		Minimum at any point	
AWG/kcmil	mm	mils	mm	mils
14 – 9 AWG	0.38	15	0.30	12
8 – 2 AWG	0.76	30	0.61	24
1 – 4/0 AWG	1.14	45	0.91	36
213 – 500 kcmil	1.65	65	1.32	52

**Table 35**  
**Thickness of Overall Polyethylene Jacket for Deep-Well Submersible Water Pump Cables**  
**(See Clause 7.2.3.)**

Diameter of cable under jacket of round configuration or major dimension of flat configuration	Jacket thickness			
	Minimum average		Minimum at any point	
mm (inches)	mm	mils	mm	mils
Up to 17.8 (0.700)	1.52	60	1.21	48
17.9 – 26.7 (0.701 – 1.051)	2.03	80	1.62	64
26.8 – 38.1 (1.052 – 1.500)	2.03	80	1.62	64
38.2 – 50.1 (1.51 – 1.972)	2.79	110	2.23	88

**Table 36**  
**Physical Properties of PVC Jackets for Deep-Well Submersible Water Pump Cables**  
**(See Clause 7.2.3.)**

Condition before aging	Test	Requirements
Elongation	Minimum increase in distance between gauge marks	100 percent
Tensile strength	Minimum tensile strength	10.3 MPa (1500 lbf/in <sup>2</sup> )
<b>Condition after aging</b>	<b>Test</b>	<b>Requirements</b>
After air oven test	Temperature	100°C ± 1°C
	Time	168 h
After oil immersion	Minimum percent of values obtained on unaged specimens	Elongation 45 percent Tensile strength 65 percent
	Temperature	70°C ± 1°C
	Time	4 h
	Minimum percent of values obtained on unaged specimens	Elongation 60 percent Tensile strength 80 percent

**Table 37**  
**Tray Loading for Circular Cables Smaller than 13 mm (0.5 inch) in Diameter**  
**(See Clause 8.2.6.2.13.1.)**

Cable diameter, mm (inch)		Number of cables in each bundle	Number of bundles in tray
From	But less than		
	3 (0.12)	19	13
3 (0.12)	5 (0.20)	19	8
5 (0.20)	6 (0.24)	7	9
6 (0.24)	9 (0.35)	3	10
9 (0.35)	11 (0.43)	3	8
11 (0.43)	13 (0.51)	3	7

**Table 38**  
**Tray Loading for Circular Cables 13 mm (0.5 inch) in Diameter and Larger**  
**(See Clause 8.2.6.2.13.1.)**

Cable diameter, mm (inches)		Number of cables in tray
From	But less than	
13 (0.51)	15 (0.59)	11
15 (0.59)	19 (0.75)	9
19 (0.75)	21 (0.83)	8
21 (0.83)	26 (1.0)	7
26 (1.0)	28 (1.1)	6
28 (1.1)	39 (1.5)	5
39 (1.5)	52 (2.0)	4
52 (2.0)	73 (2.9)	3
73 (2.9)	120 (4.7)	2

**Table 39**  
**Conversion of Percent Transmittance to Specific Optical Density**  
**(See Clause 8.2.7.1.6.)**

Parameters and range of transmittance (T)	Percent T	0	1	2	3	4	5	6	7	8	9
		Specific optical density (D)									
Multiplier 100 with ND-2 filter 100 at 10 percent T	90	6	5	5	4	4	3	2	2	1	1
	80	13	12	11	11	10	9	9	8	7	7
	70	20	20	19	18	17	16	16	15	14	14
	60	29	28	27	26	26	25	24	23	22	21
	50	40	39	37	36	35	34	33	32	31	30
	40	53	51	50	48	47	46	45	43	42	41
	30	69	67	65	64	62	60	59	57	55	54
	20	92	89	87	84	82	79	77	75	73	71
10	132	127	122	117	113	109	105	102	98	95	

Table 39 Continued

Parameters and range of transmittance (T)	Percent T	0	1	2	3	4	5	6	7	8	9
		Specific optical density (D)									
Multiplier 10 with ND-2 filter 10 at 1 percent T	90x10 <sup>-1</sup>	138	137	137	136	136	135	134	134	133	133
	80	145	144	143	143	142	141	141	140	139	139
	70	152	152	151	150	149	148	148	147	146	146
	60	161	160	159	158	158	157	156	155	154	153
	50	172	171	169	168	167	166	165	164	163	162
	40	185	183	182	180	179	178	177	175	174	173
	30	201	199	197	196	194	192	191	189	187	186
	20	224	221	219	216	214	211	209	207	205	203
	10	264	259	254	249	245	241	237	234	230	227
Multiplier 10 with ND-2 filter 1 at 0.1 percent T	90x10 <sup>-2</sup>	270	269	269	268	268	267	266	266	265	265
	80	277	276	275	275	274	273	273	272	271	271
	70	284	284	283	282	281	280	280	279	278	278
	60	293	292	291	290	290	289	288	287	286	285
	50	304	303	301	300	299	298	297	296	295	294
	40	317	315	314	312	311	310	309	307	306	305
	30	333	331	329	328	326	324	323	321	319	318
	20	356	353	351	348	346	343	341	339	337	335
	10	396	391	386	381	377	373	369	366	362	359
Multiplier 0.1 with ND-2 filter 0.1 at 0.01 percent T	90x10 <sup>-3</sup>	402	401	401	400	400	399	398	398	397	397
	80	409	408	407	407	406	405	405	404	403	403
	70	416	416	415	414	413	412	412	411	410	410
	60	425	424	423	422	422	421	420	419	418	417
	50	436	435	433	432	431	430	429	428	427	426
	40	449	447	446	444	443	442	441	439	438	437
	30	465	463	461	460	458	456	455	453	451	450
	20	488	485	483	480	478	475	473	471	469	467
	10	528	523	518	513	509	505	501	498	494	491
Multiplier 1 without ND-2 filter 0.01 at 0.001 percent T	90x10 <sup>-4</sup>	534	533	533	532	532	531	530	530	529	529
	80	541	540	539	539	538	537	537	536	535	535
	70	548	548	547	546	545	544	544	543	542	542
	60	557	556	555	554	554	553	552	551	550	549
	50	568	567	565	564	563	562	561	560	559	558
	40	581	579	578	576	575	574	573	571	570	569
	30	597	595	593	592	590	588	587	585	583	582
	20	620	617	615	612	610	607	605	603	601	599
	10	660	655	650	645	641	637	633	630	626	623
Multiplier 0.1 without ND-2 filter 0.001 at 0.00001 percent T	90x10 <sup>-5</sup>	666	665	665	664	664	663	662	662	661	661
	80	673	672	671	671	670	669	669	668	667	667
	70	680	680	679	678	677	676	676	675	674	674
	60	689	688	687	686	686	685	684	683	682	681
	50	700	699	697	696	695	694	693	692	691	690
	40	713	711	710	708	707	706	705	703	702	701
	30	729	727	725	724	722	720	719	717	715	714
	20	752	749	747	744	742	739	737	735	733	731
	10	792	787	782	777	773	769	765	762	758	755
00	—	924	885	861	845	832	821	812	805	798	



**Table 40**  
**A-C Spark Test Potential**  
**(See Clause 5.22.)**

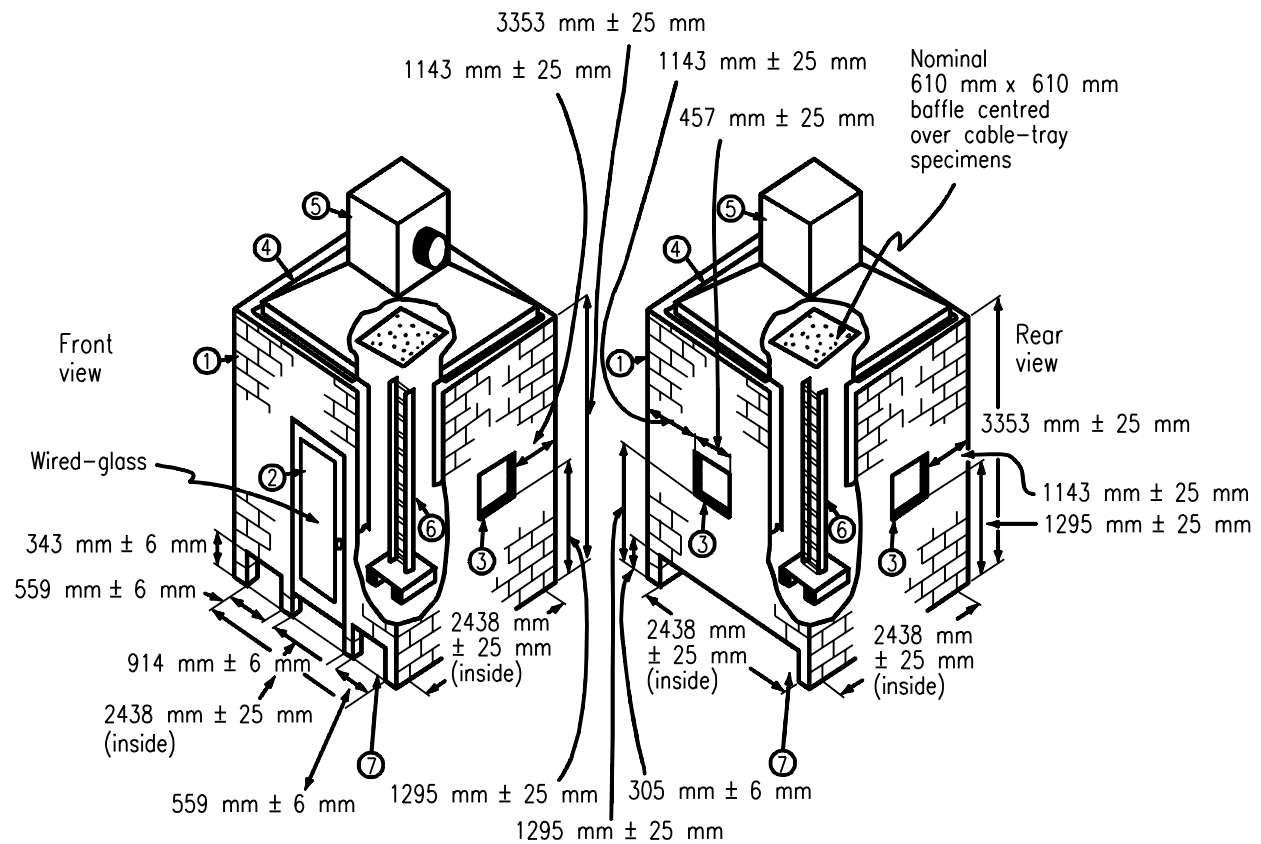
<b>Conductor size, mm<sup>2</sup> (AWG or kcmil)</b>	<b>A-C test potential (kV)</b>
2.08 – 5.26 (14 – 10)	7.5
8.37 – 33.6 (8 – 2)	10.0
42.4 – 107 (1 – 4/0)	12.5
127 – 253 (250 – 500)	15.0
279 – 507 (550 – 1000)	17.5
557 – 1010 (1100 – 2000)	20.0

**Table 41**  
**A-C Test Voltages for Dielectric Voltage-Withstand**  
**(See Clause 5.23.1.)**

<b>Conductor size, mm<sup>2</sup> (AWG or kcmil)</b>	<b>RMS dielectric test potential (kV)</b>
2.08 – 33.6 (14 – 2)	2.0
42.4 – 107 (1 – 4/0)	2.5
127 – 253 (250 – 500)	3.0
279 – 507 (550 – 1000)	3.5
557 – 1010 (1100 – 2000)	4.0

## Figures

**Figure 1**  
**Cable Test Enclosure and Exhaust Duct**  
 (See Clauses 8.2.6.1.2 and 8.2.6.2.2.)

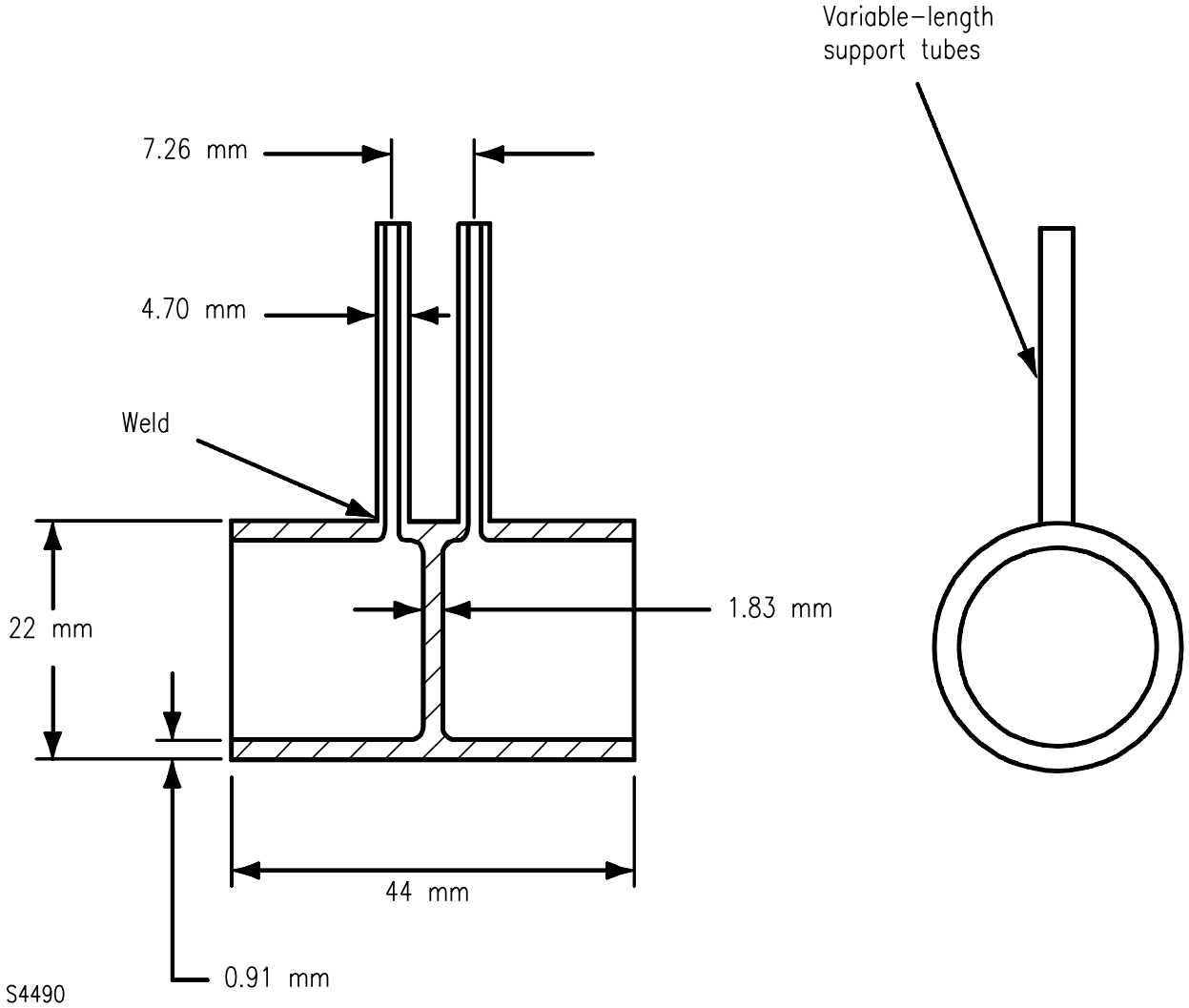


**Legend:**

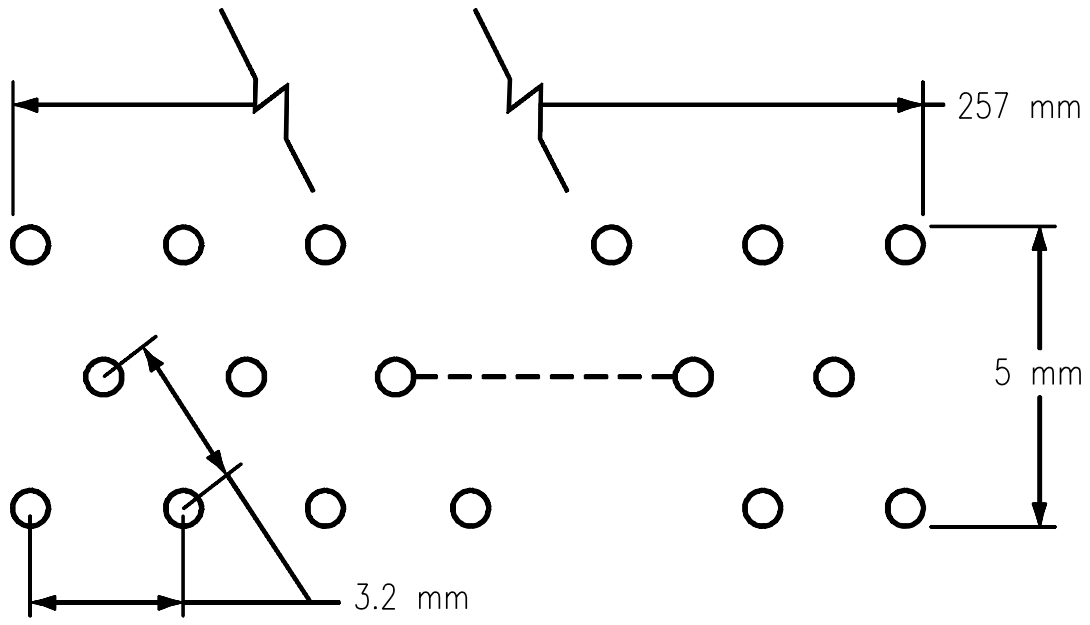
- 1 - Enclosure constructed of concrete blocks laid up with mortar. The blocks shall be nominally 203 mm high x 406 mm long x 152 mm thick (8 in x 16 in x 6 in).
- 2 - Steel-framed wired-glass door for access and observation. The overall size of the door shall be nominally 0.9 m wide x 2.1 m high (36 in x 84 in).
- 3 - Square steel-framed wired-glass observation window(s) nominally 457 mm (18 in) on a side.
- 4 - Truncated-pyramid stainless-steel hood. Each side shall be sloped 40°.
- 5 - Collection box with exhaust duct centered in one side. The box shall be a cube with each face a 914 mm (36 in) square.
- 6 - Cable tray mounted vertically in the center of the enclosure. The tray base stand shall be optional and shall not be higher than 152 mm (6 in).
- 7 - Air-intake openings.

S4489A

**Figure 2**  
**Bi-directional Probe**  
(See Clauses 8.2.6.1.3 and 8.2.6.2.3.)

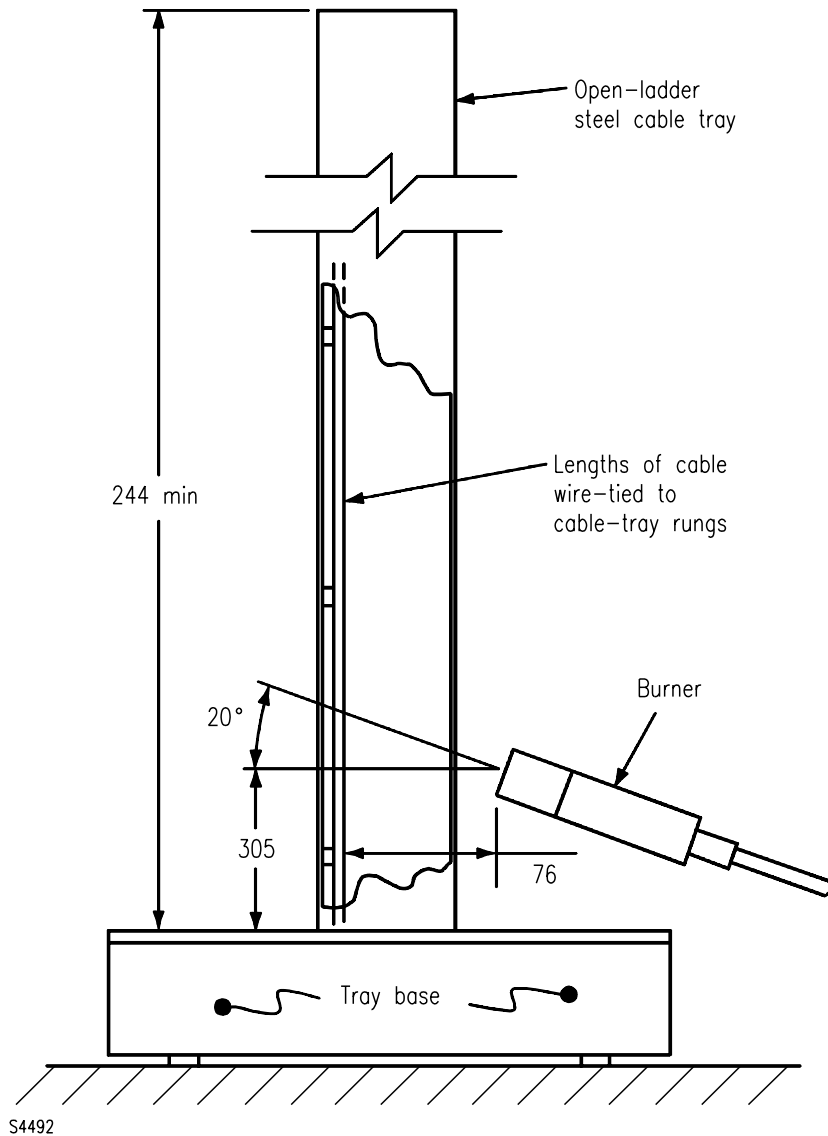


**Figure 3**  
**Burner Holes**  
(See Clauses 8.2.6.1.5 and 8.2.6.2.5.)



S4491

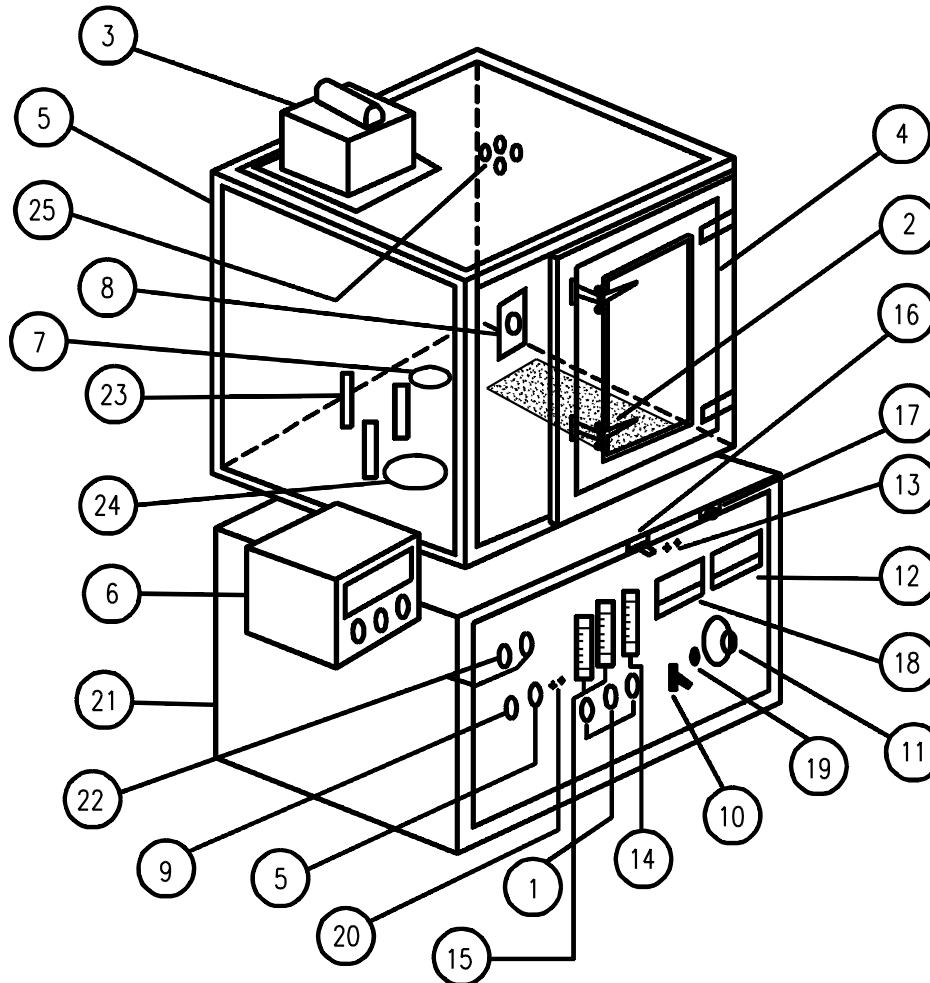
**Figure 4**  
**Cable Tray, Specimen, and Burner Details**  
 (See Clauses 8.2.6.2.4, 8.2.6.2.5, and 8.2.6.2.14.2.)



**Notes:**

- (1) Cable tray – Nominally 305 mm wide x 76 mm deep x 2440 mm long with steel rungs nominally  $25 \pm 6$  mm wide and spaced 229 mm on centers.
- (2) Burner – 254 mm (10 inches) wide ribbon-type burner with an air/gas venturi mixer.
- (3) Tray Base – Optional. 152 mm maximum height.
- (4) Dimensions are in millimeters.

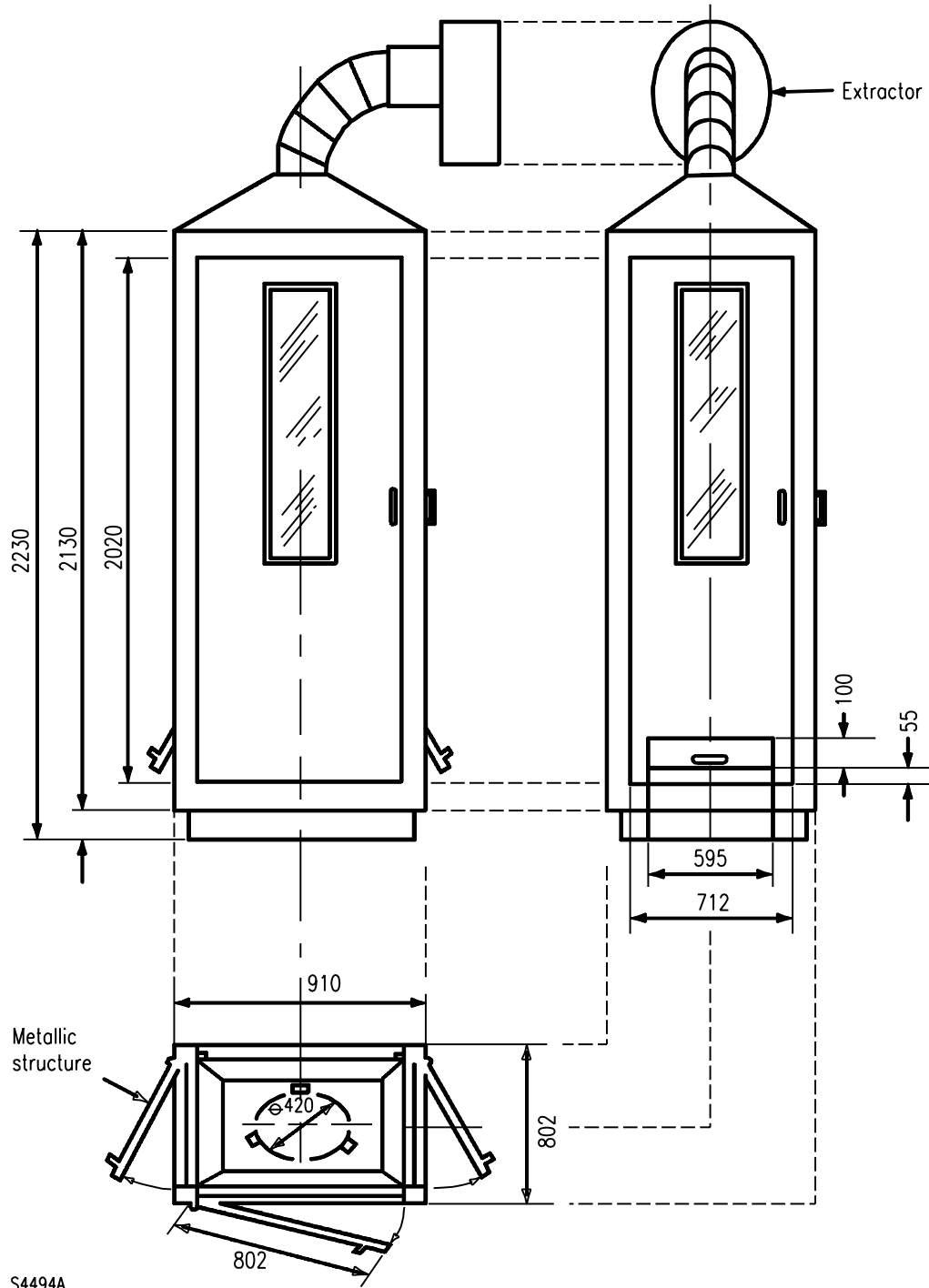
**Figure 5**  
**Chamber for Smoke Emission Test**  
 (See Clauses 8.2.7.1.2, 8.2.7.1.4, and 8.2.7.1.5.2.)



**Legend:**

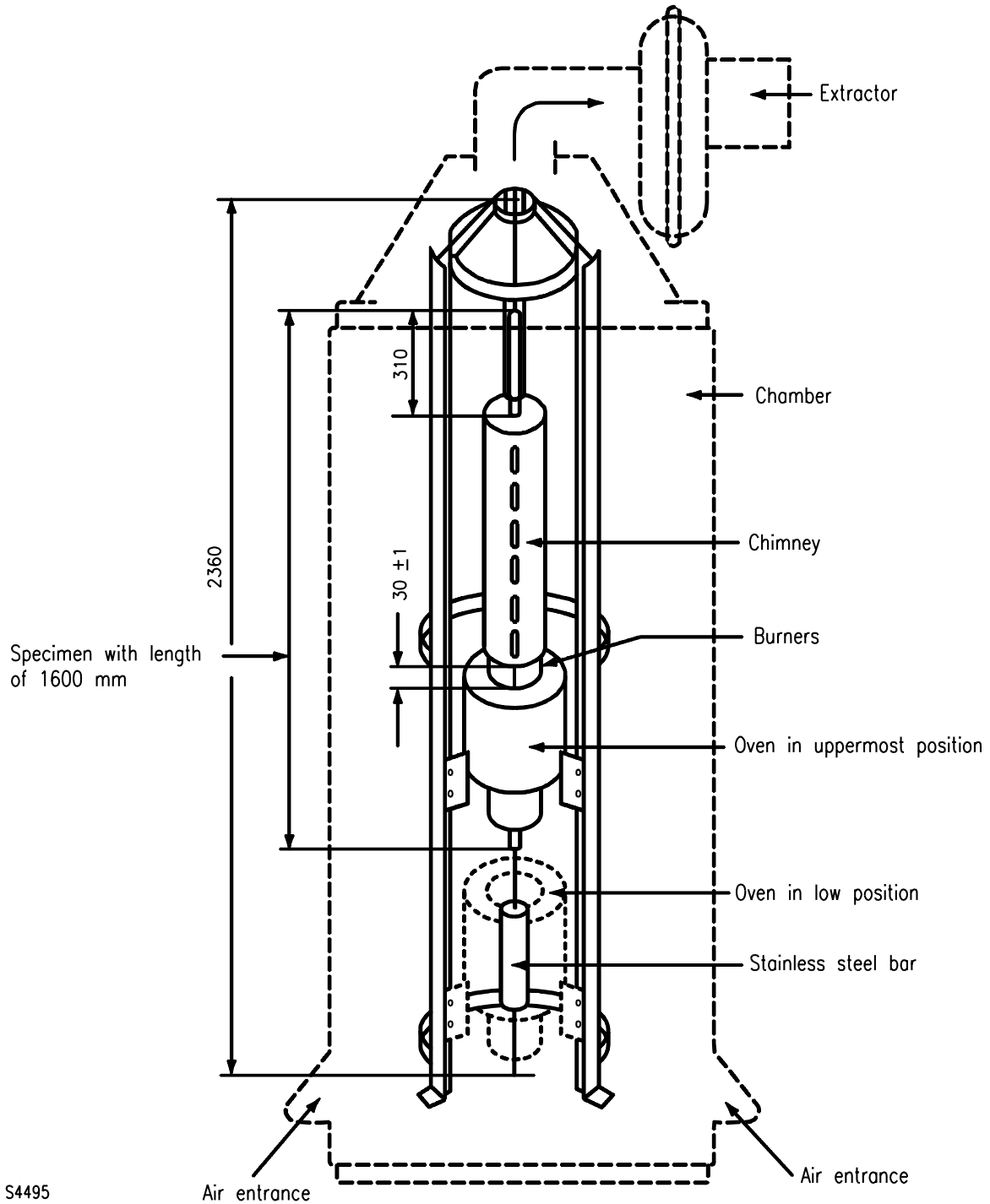
- |  |   |
|--|---|
| 1 Burner air valve and rotator                     | 14 Radiometer air valve and rotator                   |
| 2 Safety seal (aluminum foil)                      | 15 Gas valve and rotator (burner)                     |
| 3 Photomultiplier tube stopper                     | 16 Smoke extraction system control                    |
| 4 Photomultiplier tube filter                      | 17 Positioning rod knob                               |
| 5 Lamp switch                                      | 18 Measuring equipment of voltage from oven radiation |
| 6 Photomultiplier                                  | 19 Fuses  |
| 7 Smoke extraction system                          | 20 Lamp supply inlets                                 |
| 8 Ventilator window                                | 21 Cabinet base                                       |
| 9 Main switch                                      | 22 Indicator lamps                                    |
| 10 Heater switch                                   | 23 Optical system bars                                |
| 11 Voltage adjustment knob                         | 24 Floor window of optical system                     |
| 12 Measurer of chamber wall temperature            | 25 Access doors                                       |
| 13 Inlet for millivolt measurement from radiometer |   |

**Figure 6**  
**Chamber for Fire Propagation Test**  
 (See Clause 8.2.7.2.1.1.)



**Note:** Dimensions in millimeters.

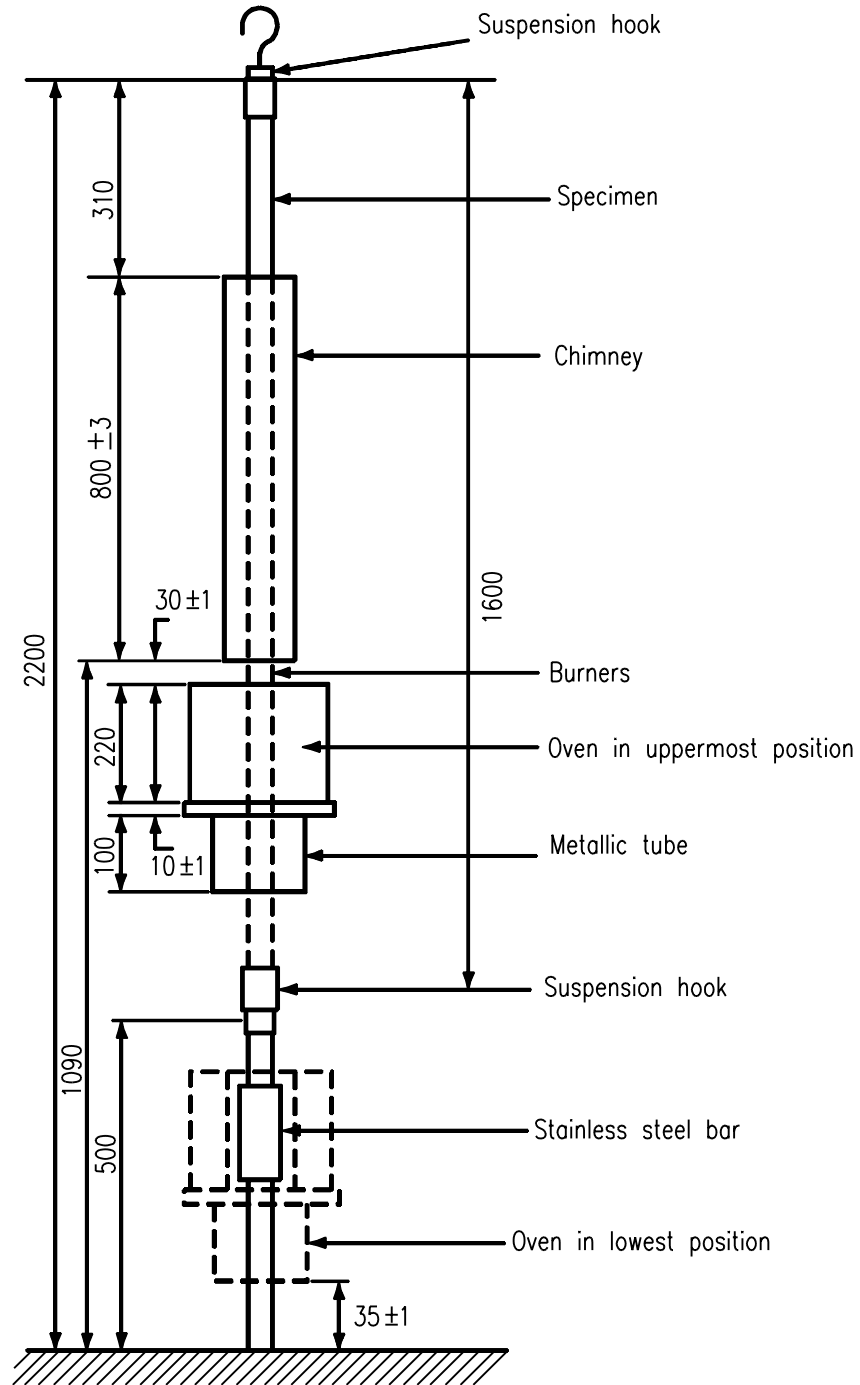
**Figure 7**  
**Detail 1 of Dimensions for Fire Propagation Test Chamber**  
 (See Clause 8.2.7.2.1.1.)



**Note:** Dimensions in millimeters.



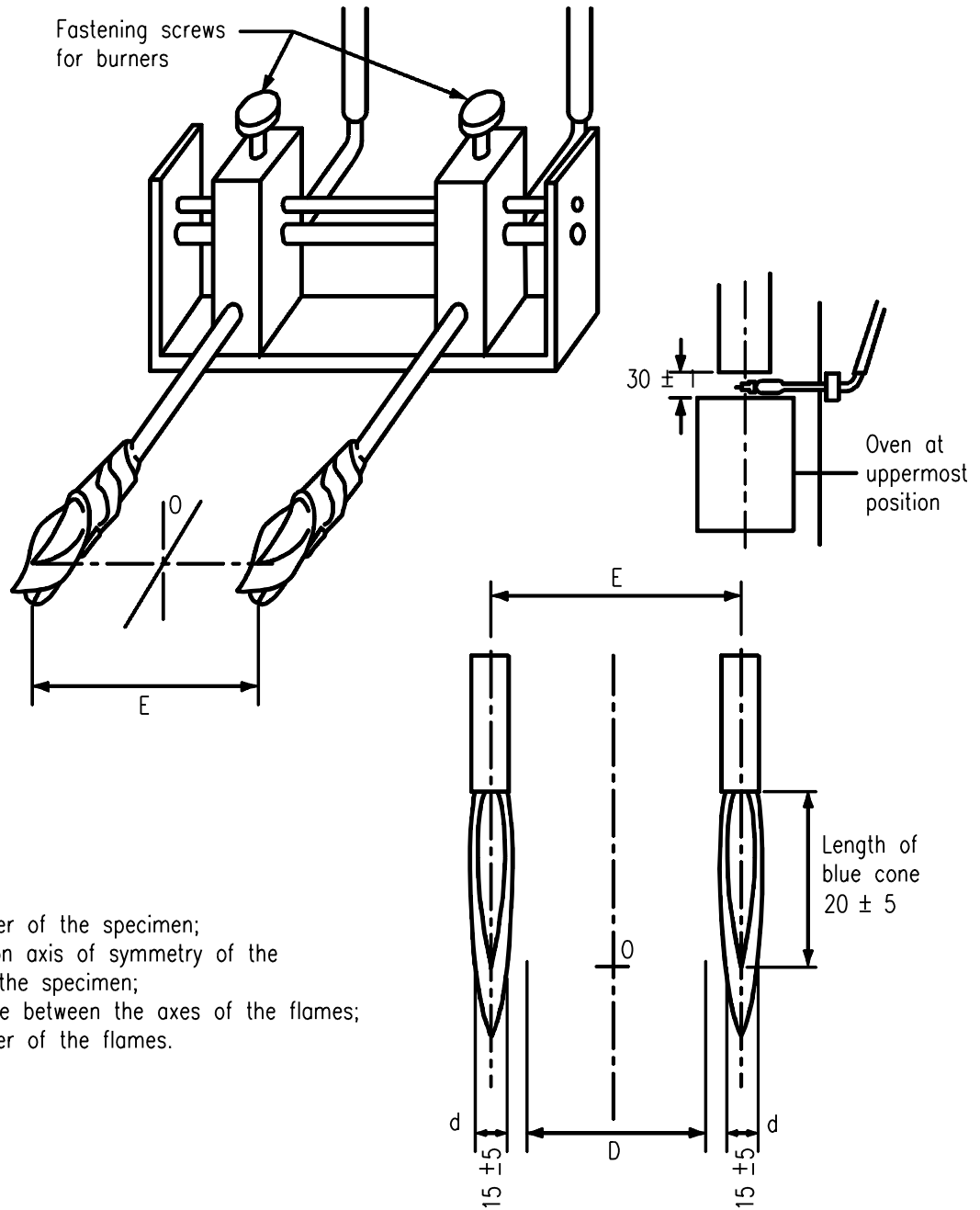
**Figure 8**  
**Detail 2 of Dimensions for Fire Propagation Test Chamber**  
 (See Clause 8.2.7.2.1.1.)



S4496

**Note:** Dimensions in millimeters.

**Figure 9**  
**Burners for Fire Propagation Test**  
 (See Clause 8.2.7.2.1.1.)



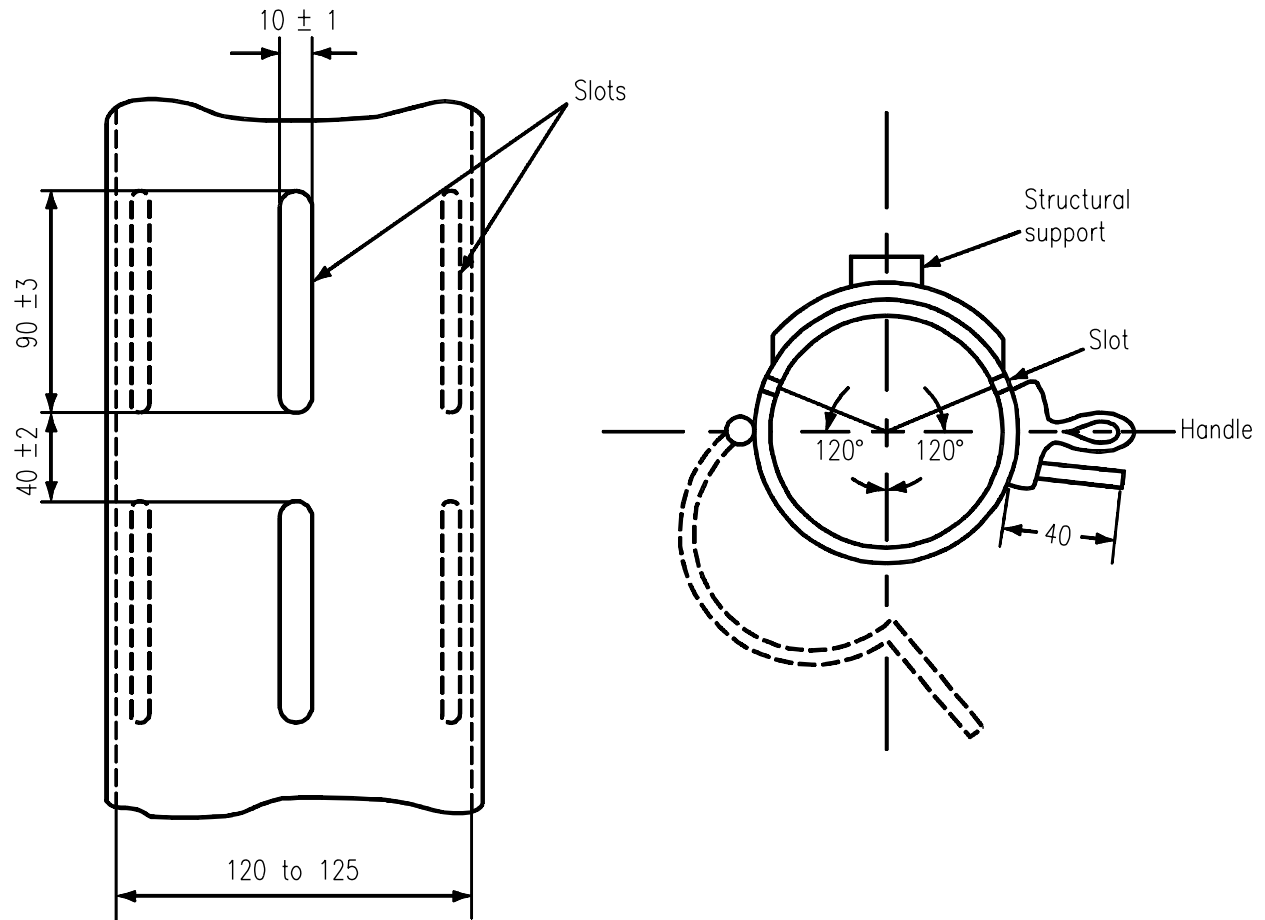
**Legend:**

- D is the diameter of the specimen;
- O is the common axis of symmetry of the chimney and the specimen;
- E is the distance between the axes of the flames;
- d is the diameter of the flames.

S4497

**Note:** Dimensions in millimeters.

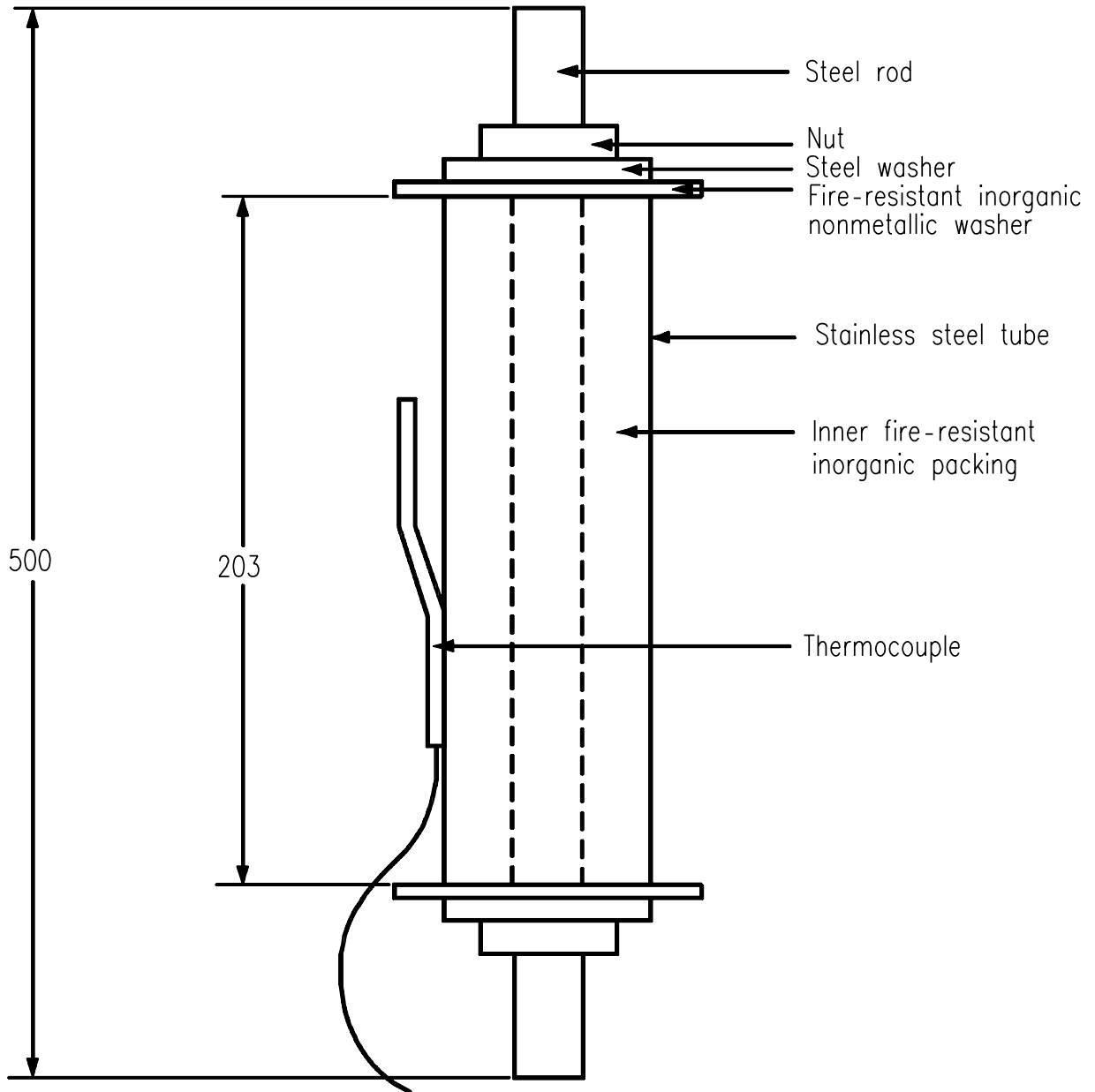
**Figure 10**  
**Metallic Chimney of Fire Propagation Test Chamber**  
(See Clause 8.2.7.2.1.1.)



S4498

**Note:** Dimensions in millimeters.

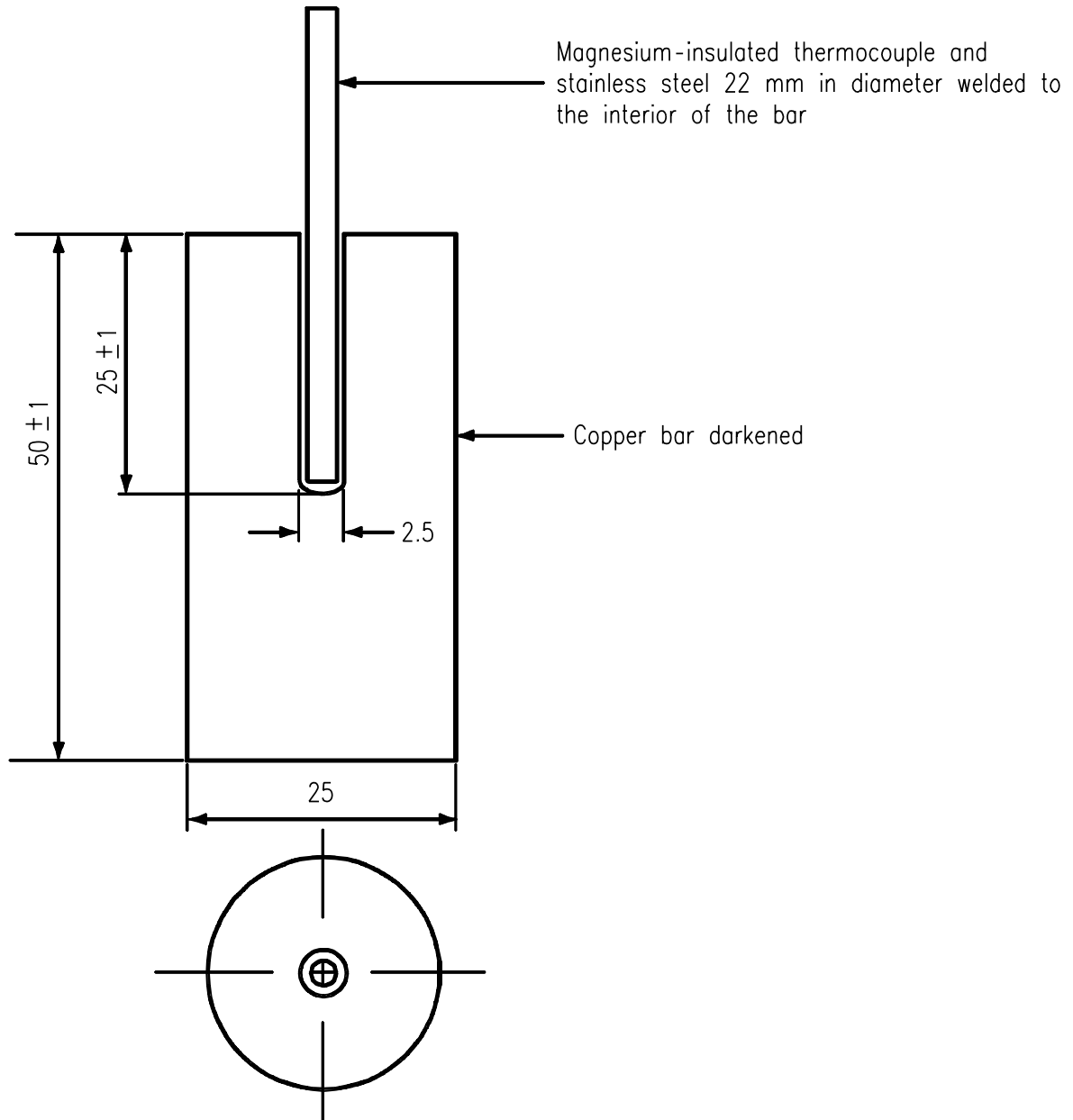
**Figure 11**  
**Stainless Steel Tube in Fire Propagation Test Chamber**  
(See Clause 8.2.7.2.1.1.)



S4499A

**Note:** Dimensions in millimeters.

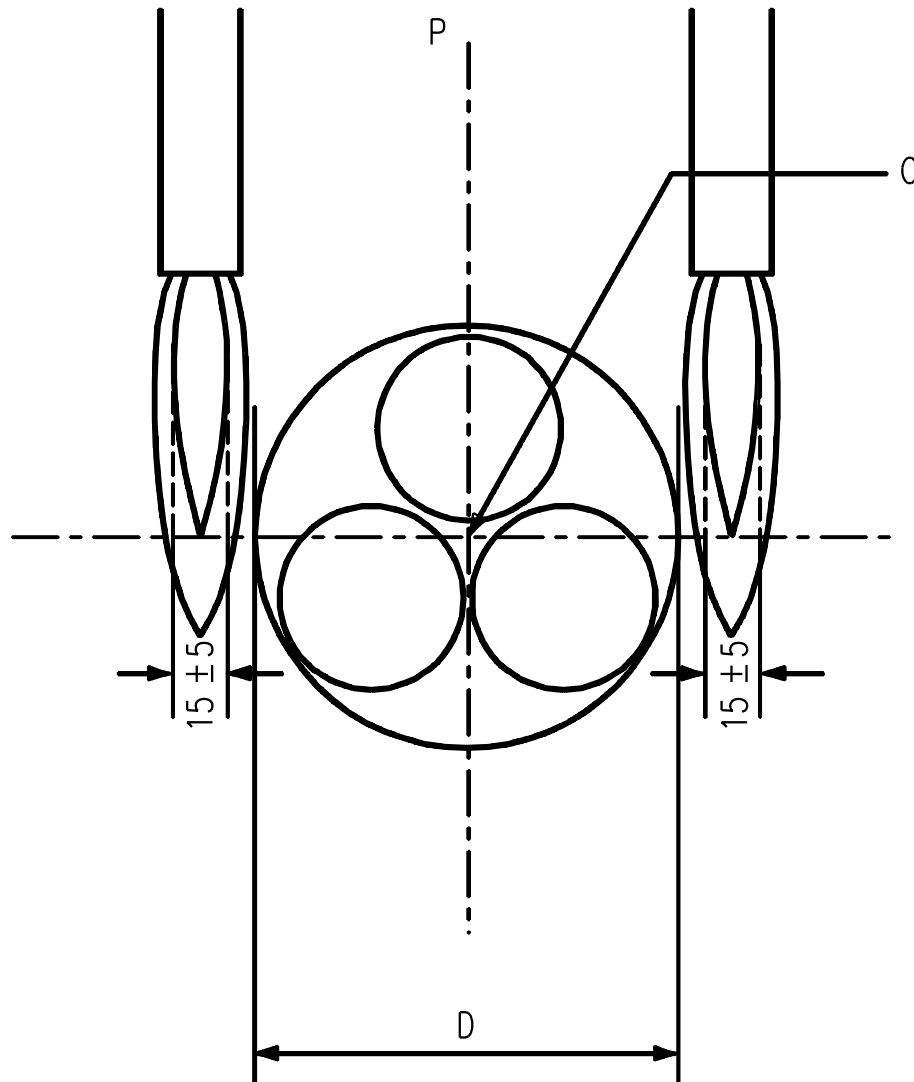
**Figure 12**  
**Copper Bar for Flame Temperature Calibration in Fire Propagation Test**  
 (See Clauses 8.2.7.2.1.1 and 8.2.7.2.2.3.)



S4500

**Note:** Dimensions in millimeters.

**Figure 13**  
**Arrangement of Specimen between Burners Used in Fire Propagation Test Chamber**  
(See Clause 8.2.7.2.3.)



**Legend:**

O is the common axis of symmetry between chimney and oven;

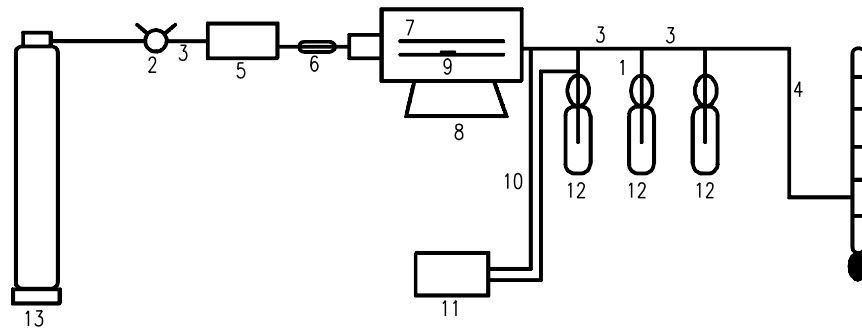
P is the plane of symmetry of the valves;

D is the diameter of the specimen.

S4501

**Note:** Dimensions in millimeters.

**Figure 14**  
**Combustion System for Halogen Acid Gas Emission Test Procedure**  
 (See Clauses 8.2.7.3.2.1 and 8.2.7.3.4.)

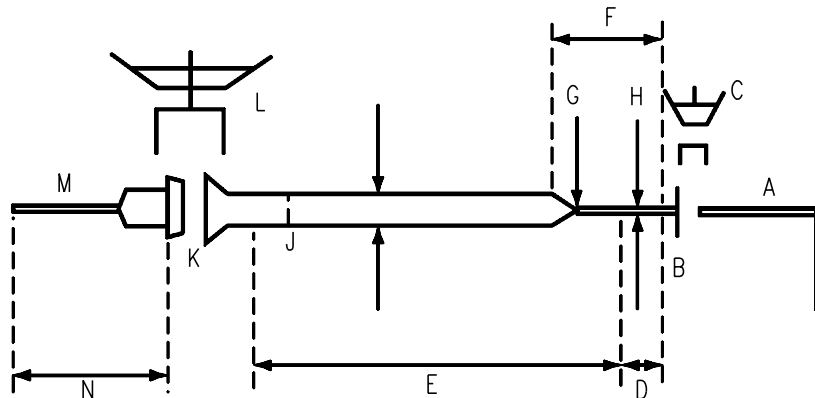


**Legend:**

- [1] Dry air tank
- [2] Regulator
- [3] Silicone tubing
- [4] Latex tubing
- [5] Flow controller (lever or knob)
- [6] Connector
- [7] Combustion tube
- [8] Tubular oven with uniform temperature rise control capable of reaching 1000°C: minimum 30 cm in length
- [9] Crucible (combustion bay) approximately 7.6 x 1.0 x 0.9 cm
- [10] Heating element 2.5 x 120 cm with glass fiber insulation, capable of maintaining a temperature of 200°C in the glass ducting
- [11] Rheostat
- [12] Wash traps 5.5 ± 0.5cm in diameter
- [13] Flowmeter with 0–200 ml/min capacity

S4502

**Figure 15**  
**Quartz Combustion Tube**  
 (See Clause 8.2.7.3.2.1.)



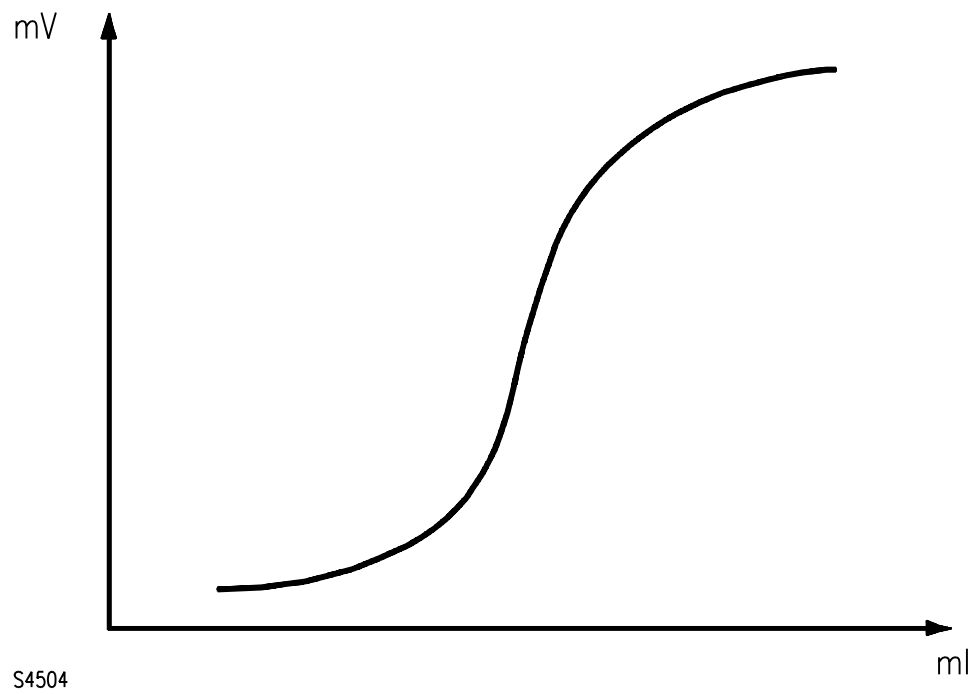
**Legend:**

- |   |   |
|---|---|
| A) Connection between borosilicate and circular packing | H) Outside diameter, 17 mm                              |
| B) Circular packing 29/9 male and female                | I) Outside diameter, 25 mm                              |
| C) Pliers for circular packing                          | J) Inside diameter, 19 mm                               |
| D) Length of tube overhanging from the oven, 30–50 mm   | K) Circular packing, 35/25 male and female              |
| E) Portion of tube inside the oven (length of oven)     | L) Pliers for circular packing No. 35                   |
| F) Length of low diameter (100–120 mm)                  | M) Connection between borosilicate and circular packing |
| G) Internal diameter, 13 mm                             | N) Length of borosilicate connection, 50–100 mm         |

S4503

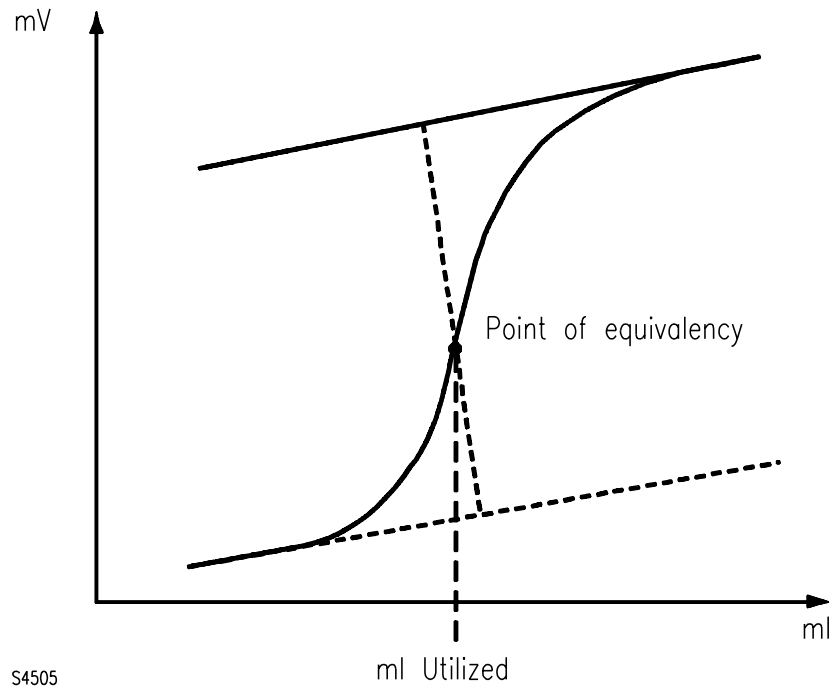
**Graphs**

**Graph 1**  
**Typical Titration Graph for Halogen Acid Gas Emission**  
(See Clauses 8.2.7.3.6.1.)

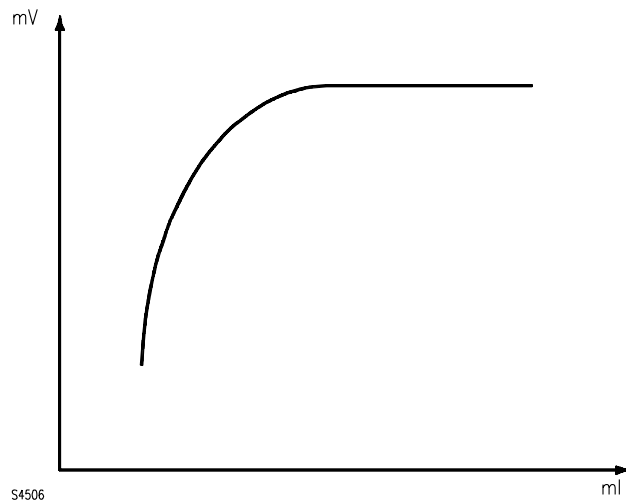




**Graph 2**  
**Geometric Determination of the Point of Equivalency of Halogen Acid Gas Emission**  
(See Clauses 8.2.7.3.6.1 and 8.2.7.3.6.2.)



**Graph 3**  
**Typical Null Titration Curve for Halogen Acid Gas Emission**  
(See Clause 8.2.7.3.6.2.)



**Note:** As shown in this graph, a similar response to the upper end of the curve of Graph 2 is obtained; that is to say, the curve records the behavior the reaction represented in Graph 2 exhibits after the point of equivalency. Given that halogens do not appear in the solution in the blank titration, the potential will be given only for the calculated quantity of silver nitrate solution.

**Annex A (informative)**  
**Wire Type and Electrical Code Cross-Reference and Summary of Applications**

(See Clause 1.1.)

**Table A1**  
**Wire Type/Electrical Code Cross-Reference Chart**  
(See Clause 1.1.)

Wire type designation	Electrical code		
	Canada <i>Canadian Electrical Code (CEC)</i>	Mexico <i>Standard for Electrical Installations (NOM-001-SEDE)</i>	United States <i>National Electrical Code (NEC)</i>
TW	YES	YES	YES
TWU	YES	NO	NO
TWU75	YES	NO	NO
THW	NO	YES	YES
TW75	YES	NO	NO
THW-2	NO	YES	YES
THW-LS	NO	YES	NO
THHW	NO	YES	YES
THHW-LS	NO	YES	NO
THHN	NO	YES	YES
T90 NYLON	YES	NO	NO
THWN-2	NO	YES	YES
THWN	NO	YES	YES
TWN75	YES	NO	NO

**Note:**  
(1) This table is accurate at the date of publication. Subsequent changes in any national code will supersede this table. See Clause 6.1.3.2 for multiple type designation markings.

**Annex B (normative for Mexico)**  
**Multiple-Conductor Thermoplastic-Insulated and -Jacketed Cables**

(See Clause 1.3.)

**Note:** *In Canada and the United States, this Annex does not apply.*

## **B1 Scope**

### **B1.1 General**

This Annex specifies the requirements for multiple-conductor thermoplastic-insulated and -jacketed cables rated 600 V.

### **B1.2 Single conductors**

Single conductors composing the multiple-conductor cables shall be of the Types specified in Table 1 of this Standard.

## **B2 Lay of cabled conductors**

B2.1 Two or more conductors in a multiple-conductor cable shall be assembled in accordance with Clauses B2.2 and B2.3.

B2.2 The component wires or cables of a two-conductor cable shall be assembled as follows:

- a) all cables in sizes larger than 13.3 mm<sup>2</sup> (6 AWG) cabled in accordance with Clause B2.3;
- b) all cables in sizes 13.3 mm<sup>2</sup> (6 AWG) and smaller cabled in accordance with Clause B2.3 or parallel.

B2.3 A multiple-conductor cable, other than two-conductor parallel cable, shall have the finished insulated conductors cabled together with a length of lay not greater than indicated in Table B1. The direction of lay shall be allowed to be changed at intervals throughout the length of the cable. The intervals need not be uniform in a cable in which the direction of lay is changed.

The following requirements shall apply:

- a) Each area in which the lay is right- or left-hand for a minimum of 5 complete twists (full 360° cycles) shall have the insulated conductors cable with a length of lay not greater than that indicated in Table B1;
- b) The length of each lay-transition zone (oscillated section) between these areas of right- and left-hand lay shall not exceed 1.8 times the maximum length of lay indicated in Table B1.

The overall diameter of the assembly, where required, shall be calculated as outlined in Clause B7.2.

If the assembly consists of number of layers of insulated conductors, the direction of lay of the outer layer is either left-hand or right-hand, and the direction of lay of successive layers is reversed.

### **B3 Equipment-grounding conductor**

Equipment-grounding conductors shall not be smaller than the sizes shown in Table B2. Where multiple equipment-grounding conductors are employed, they shall have a combined area not less than the sizes given in Table B2. In cables containing more than one size of circuit conductor, the minimum equipment-grounding conductor size shall be determined by the size of the largest circuit conductor.

The equipment-grounding conductor shall be of the same stranding class as that of the accompanying circuit conductors or of a more flexible stranding class.

### **B4 Conductor identification**

#### **B4.1 Color of insulated grounding conductor**

A single-conductor insulated wire or cable intended for use as an equipment- grounding conductor and any insulated equipment-grounding conductor provided in an assembly containing two or more insulated circuit conductors shall be finished to show the color green throughout the entire length and circumference of its outer surface, with or without one or more straight or helical, broken (non-continuous) or unbroken yellow stripes. No circuit conductor in the cable shall be green.

#### **B4.2 Identification of ungrounded (phase) conductor(s)**

Each ungrounded (phase) conductor in the cable shall be finished to show a color other than white, gray, or green.

#### **B4.3 Identification of grounded conductor(s)**

If one or more conductors are intended for use as a grounded circuit conductor, they shall be finished to show the color white or light gray throughout the entire length and all the circumference of its outer surface.

### **B5 Fillers**

Fillers when used in a multiple-conductor cable or assembly shall be of non-hygroscopic material and shall not have any deleterious effect on other cable components.

### **B6 Jacket separators**

B6.1 A polymeric tape of non-hygroscopic material having a thickness of not less than 0.02 mm shall be optional for use under the jacket. The separator and other wire or cable components shall not have any deleterious effect on each other.

B6.2 The tape shall be applied either helically or longitudinally to completely cover the underlying components so that it has an overlap of not less than 25 percent.

### **B7 Jackets**

#### **B7.1 General**

A multiple-conductor cable shall have a protective jacket applied over the cabled conductors or over a jacket separator. The physical properties of the jacket shall comply with Table B3.

## B7.2 Jacket thickness

The average and minimum thickness of a jacket shall not be less than indicated in Table B4 when determined by the method described in UL 1581, Section 240; CSA C22.2 No. 0.3, Clause 4.2.1; or NMX-J-177-ANCE. The minimum thickness measured at any point shall not be less than 80 percent of the nominal thickness.

## B8 Marking

### B8.1 Marking on product

Multiple-conductor cables shall be legibly and durably marked to indicate the following:

- a) Manufacturer's identification;
- b) Conductor type;
- c) Number of circuit conductors;
- d) Conductor size in mm<sup>2</sup> (AWG or kcmil);
- e) Voltage rating, volts;
- f) Maximum operating dry and wet temperature rating of insulation, °C;
- g) Optional markings where applicable\* (e.g., LS, CT, etc.).

*\* Corresponding tests shall be performed on the finished cable.*

### B8.2 Marking on package

Each package of multiple-conductor cable shall be tagged or marked legibly and durably to indicate the following:

- a) Manufacturer's identification;
- b) Number of circuit conductors;
- c) Conductor size in mm<sup>2</sup> (AWG or kcmil);
- d) Conductor type designation;
- e) Material of the jacket;
- f) Voltage rating, volts;
- g) Maximum operating dry and wet temperature rating of insulation, °C.

**Table B1**  
**Maximum Length of Lay for Multiple-Conductor Cables**  
**(See Clause B2.3.)**

Number of conductors	Maximum length of lay
2	30 times diameter of finished insulated conductor
3	35 times diameter of finished insulated conductor
4	40 times diameter of finished insulated conductor
5 or more, or assemblies with more than one conductor size	15 times the overall diameter of the assembly, except that in a multiple layer cable, the length of lay of the conductors in any inner layer shall be not more than 20 times the overall diameter of that layer.

**Table B2**  
**Minimum Size of Equipment-Grounding Conductor**  
**(See Clause B3.)**

Size of circuit conductor (phase)		Minimum size of grounding conductor	
Cross-sectional area mm <sup>2</sup>	AWG or kcmil	Cross-sectional area mm <sup>2</sup>	AWG
2.08 – 5.26	14 – 10	The same size as circuit conductor	
8.37	8	5.26	10
13.3 – 21.2	6 – 4	8.37	8
33.6 – 67.4	2 – 2/0	13.3	6
85.0 – 203	3/0 – 400	33.6	2
253 – 507	500 – 1000	42.4	1

**Table B3**  
**Physical Properties of Thermoplastic Jackets**  
**(See Clause B7.1.)**

Condition before aging	Test	Requirements
Elongation	Minimum increase in distance between gauge marks	100 percent
Tensile strength	Minimum tensile strength	10.3 MPa
Condition after aging after air-oven test	<b>Test</b>	<b>Requirements</b>
	Temperature	100°C ± 1°C
	Time	168 h
	Minimum percent of values obtained on unaged specimens	Elongation 45 percent Tensile strength 65 percent
After oil immersion	<b>Test</b>	<b>Requirements</b>
	Temperature	70°C ± 1°C
	Time	4 h
	Minimum percent of values obtained on unaged specimens	Elongation 60 percent Tensile strength 80 percent

**Table B4**  
**Jacket Thickness**  
**(See Clause B7.2.)**

Calculated diameter under jacket of round cable or calculated length of major axis under jacket of 2-conductor flat parallel.		Thickness of jacket			
		Average		Minimum at any point	
		mm	mils	mm	mils
0 – 10.80	0 – 0.425	1.14	45	0.91	36
10.81 – 17.80	0.426 – 0.700	1.52	60	1.22	48
17.81 – 38.10	0.701 – 1.500	2.03	80	1.62	64
38.11 – 63.50	1.501 – 2.500	2.79	110	2.23	88
Over 63.50	Over 2.500	3.56	140	2.85	112

**Annex C (informative)  
Summary of Requirements**

**Table C1  
(See Clause 3.3.)**

Wire Type Designation →	TW	THW or TW75, THW-2, THHW, THW-LS, THHW-LS	THWN or TWN75, THWN-2	THHN or T90 Nylon	TWU	TWU75
Requirement ↓						
Maximum temperature	60°C dry or wet	THW or TW75 75°C dry or wet; THW-2 90°C dry or wet; THHW 90°C dry or 75°C wet	THWN or TWN75 75°C dry or wet; THWN-2 90°C dry or wet	90°C dry	60°C dry or wet	75°C dry or wet
Maximum voltage	600 V					
Number of conductors	(1.1 – 1.2)					
Conductor metal	(4.1.1 – 4.1.4)					
Conductor size	(4.1.5.1, Table 1)					
Conductor stranding	(4.1.5.2, Tables 1, 2 and 3)					
Conductor diameter	(4.1.6, Tables 4 – 9)					
Conductor joints	(4.1.7)					
Conductor separator	(4.1.8)					
Insulation (4.2)	PVC					
Nylon jacket	optional		required		optional	
Insulation - general	(4.2.1)					
Polarity identification	(4.2.3.2 and 4.2.3.3)					
Insulation thickness	(4.2.4, Table 10)					
Physical properties of insulation	(4.2.5, Table 11)					
Nylon jacket thickness (4.3)	–		Table 13		–	
Assemblies	(4.4)					
Conductor resistance	(5.2)					
Aluminum conductors – physical properties	(5.3.1)					

Table C1 Continued on Next Page



Table C1 Continued

Wire Type Designation →	TW	THW or TW75, THW-2, THHW, THW-LS, THHW-LS	THWN or TWN75, THWN-2	THHN or T90 Nylon	TWU	TWU75
Requirement ↓						
Aluminum conductors – high current heat cycling	(5.3.2)					
Short-term insulation resistance at elevated temperature in water	(5.4, Table 23)			Not required	(5.4, Table 23)	
Long-term insulation resistance in water	(5.5, Table 23)			Not required	(5.5, Table 23)	
Long-term insulation resistance in air for 90°C rated conductors	–			(5.6, Table 24)	–	
Capacitance and relative permittivity	(5.7)			Not required	(5.7)	
Flexibility at room temperature after aging	(5.8)					
Heat shock	(5.9)					
Cold bend	(5.10.1)					
Cold impact (optional)	(5.10.2)					
Deformation	(5.11)					
Vertical flame	(5.12.1)					
FT1 (optional)	(5.12.2)					
VW-1 (optional)	(5.12.3)					
Vertical tray (optional)	(5.12.4)					
FT4 vertical tray (optional)	(5.12.5)					
ST1 limited smoke (optional)	(5.12.6)					
LS (low smoke): flame, smoke, and acid gas release for types marked "LS" (5.12.7)	–	Required for THW-LS and THHW-LS	–			

Table C1 Continued on Next Page

Table C1 Continued

Wire Type Designation →	TW	THW or TW75, THW-2, THHW, THW-LS, THHW-LS	THWN or TWN75, THWN-2	THHN or T90 Nylon	TWU	TWU75
Requirement ↓						
Weather resistance (optional)	(5.13)					
Oil resistance (optional)	(5.14)					
Gasoline and oil resistance (optional)	(5.15)					
Abrasion resistance	–		(5.16)			
Crushing resistance	–		(5.17)			
Impact resistance	–		(5.18)			
Durability of ink printing	(5.19)					
Color coating	(5.20)					
Spark test	(5.22)					
Dielectric voltage-withstand in water	(5.23)					
Insulation resistance in water at 15°C	(5.24)					
Electrical continuity	(5.25)					
Marking on product	(6.1)					
Marking on package	(6.2)					
Deep-well submersible water pump cable – specific requirements and permitted constructions	(7)					
Multiple-conductor cable for use in Mexico	Annex B					

**Annex D (normative)**  
**Chemical Composition of Recognized ACM or AA 8000 Series Aluminum Alloy Conductor**  
**Materials**

**Table D1**  
**Chemical Composition of Recognized ACM or AA 8000 Series Aluminum Alloy Conductor**  
**Materials**

Alloys		Composition, Percent Mass							Others	
ANSI	UNS	Aluminum	Silicon	Iron	Copper	Magnesium	Zinc	Boron	Each	Total
8017	A98017	Remainder	0.10	0.55 – 0.8	0.10 – 0.20	0.01 – 0.05	0.05	0.04	0.03 <sup>a</sup>	0.10
8030	A98030	Remainder	0.10	0.30 – 0.8	0.15 – 0.30	0.05	0.05	0.001 – 0.04	0.03	0.10
8076	A98076	Remainder	0.10	0.6 – 0.9	0.04	0.05	0.5	0.04	0.03	0.10
8130	A98130	Remainder	0.15 <sup>b</sup>	0.40 – 1.0 <sup>b</sup>	0.05 – 0.15	–	0.10	–	0.03	0.10
8176	A98176	Remainder	0.03 – 0.15	0.40 – 1.0	–	–	0.10	–	0.05 <sup>c</sup>	0.15
8177	A98177	Remainder	0.10	0.25 – 0.45	0.04	–	0.05	0.04	0.03	0.10

<sup>a</sup> 0.003 max lithium.  
<sup>b</sup> 1.0 max silicon and iron.  
<sup>c</sup> 0.03 max gallium.

## **Annex E (normative)** **Copper-Clad Aluminum Conductors**

(See Clause 4.1.3.)

### **E1 General**

The copper cladding shall be metallurgically bonded to the aluminum core; shall occupy 10 percent or more of the cross-section of a solid conductor, and of each wire (strand) of a stranded conductor; and shall be concentric with the aluminum. The thickness of the copper shall not be less than 2.56 percent of the diameter of the solid conductor or wire (strand) as determined by microscopic examination of a polished right cross-section of the round strand or round solid conductor.

### **E2 Sizes and stranding**

Conductors shall be of the same size and assembly indicated for solid or concentric stranded aluminum wire in Table 1. The number of wires in the conductors shall be in accordance with Table 2.

### **E3 Conductor resistance**

The direct-current resistance of the copper-clad aluminum conductor shall not be greater than specified for aluminum conductors in Tables 14 and 15, as appropriate.

### **E4 Physical properties**

The tensile strength of a finished copper-clad aluminum conductor tested as a unit or of the wires (strands) from a finished stranded copper-clad aluminum conductor and of a solid copper-clad aluminum conductor shall not exceed  $138 \text{ MN/m}^2$  ( $20,000 \text{ lbf/in}^2$ ) when specimens are tested at a maximum separation speed of 300 mm/min (12 in/min). The elongation of the same specimens shall not be less than 15 percent. The bench marks for the tensile and elongation test shall be placed 250 mm (10 inches) apart.

### **E5 Marking requirements**

E5.1 In addition to the marking required in Clause 6.1 and 6.2, copper-clad aluminum conductors shall be marked "AL (CU-CLAD)", "ALUM (COPPER-CLAD)", "CU-CLAD AL", or "COPPER-CLAD ALUM" wherever the size of the conductor appears on the wire, cable, or package marking.

E5.2 The following statements shall also appear on the package:

- a) "Copper-clad aluminum shall be used only with equipment marked to indicate that it is for use with aluminum conductors. Terminate copper-clad aluminum with pressure wire connectors marked for use with copper and aluminum conductors."
- b) For  $3.31 - 5.26 \text{ mm}^2$  (12 – 10 AWG) solid copper-clad aluminum: "May be used with wire-binding screws and in pressure-plate and push-in spring-type connecting mechanisms that are acceptable for use with copper conductors".
- c) "Where physical contact between any combination of copper-clad aluminum, copper, and aluminum conductors occurs in a wire connector, the connector shall be of a type marked for such intermixed use and the connection shall be limited to dry locations only."

## Annex F (informative) Metric Sizes

(See Clause 4.1.5.1.)

**Note:** This annex is not a mandatory part of this Standard but is written in mandatory language to accommodate its adoption by anyone wishing to do so.

F1 Metric sizes for wire and cable products are not recognized in the *Canadian Electrical Code, Part I*, the *National Electrical Code*, or for Mexico, NOM-001-SEDE, but are employed in some jurisdictions requiring metric-sized conductors. Tables F1 and F2 are based on IEC Publication 60228.

F2 The direct-current resistance values of conductors shall not be greater than given in Table F3, except that a plus tolerance of 2 percent is optional in the case of a conductor in a twisted multiple-conductor cable assembly.

F3 Direct-current resistance shall be determined with the test, DC resistance, in UL 2556, CSA C22.2 No. 2556, or NMX-J-212-ANCE.

F4 The thickness of insulation and jackets, and other related requirements, shall be the same as those that correspond to the AWG or kcmil closest to the metric conductor size (mm<sup>2</sup>) as shown in Table F5.

**Table F1**  
**Solid Class 1 Aluminum and Copper Conductors**  
(See Clause F1.)

Conductor area		Maximum diameter, mm
Square millimeters	Circular mils	
0.50	992	0.9
0.75	1 458	1.0
1	1 980	1.2
1.5	2 952	1.5
2.5	4 856	1.9
4	7 777	2.4
6	11 637	2.9
10	19 644	3.7
16	31 109	4.6
25	49 305	5.7
35	68 339	6.7
50	92 378	7.8
70	133 484	9.4
95	185 171	11.0
120	234 119	12.4
150	287 532	13.8

**Table F2**  
**Concentric Stranded Class 2 Aluminum and Copper Conductors**  
 (See Clause F1.)

Conductor area		Number of strands				Maximum diameter, mm
		Non-compact		Compact		
Square millimeters	Circular mils	Cu	Al	Cu	Al	
0.50	1 043	7				1.1
0.75	1 485	7				1.2
1	2 101	7				1.4
1.5	3 048	7				1.7
2.5	4 871	7		6		2.2
4	7 839	7	7	6		2.7
6	11 735	7	7	6		3.3
10	19 774	7	7	6	6	4.2
16	31 357	7	7	6	6	5.3
25	49 689	7	7	6	6	6.6
35	68 902	7	7	6	6	7.9
50	93 310	19	19	6	12	9.1
70	134 869	19	19	12	15	11
95	187 020	19	19	15	18	12.9
120	236 334	37	37	18	18	14.5
150	290 335	37	37	18	30	16.2
185	364 196	37	37	30	34	18
240	478 660	61	61	34	34	20.6
300	600 431	61	61	34	53	23.1
400	767 984	61	61	53	53	26.1
500	968 194	61	61	53	53	29.2
630	1 250 079	61	91	53	53	33.2
800	1 598 917	61	91	53	53	37.6
1 000	2 015 748	61	91	53	53	42.2

**Table F3**  
**Maximum D-C Resistance in Ohms per Kilometer at 20°C**  
 (See Clause F2.)

Conductor size mm <sup>2</sup>	Solid (Class 1)			Stranded (Class 2)		
	Aluminum	Copper		Aluminum	Copper	
		Uncoated	Coated		Uncoated	Coated
0.50	–	36.0	36.7	–	36.0	36.7
0.75	–	24.5	24.8	–	24.5	24.8
1	–	18.1	18.2	–	18.1	18.2
1.5	18.1	12.1	12.2	–	12.1	12.2
2.5	12.1	7.41	7.56	–	7.41	7.56
4	7.41	4.61	4.70	7.41	4.61	4.70
6	4.61	3.08	3.11	4.61	3.08	3.11
10	3.08	1.83	1.84	3.08	1.83	1.84
16	1.91	1.15	1.16	1.91	1.15	1.16
25	1.20	0.727	–	1.20	0.727	0.734
35	0.868	0.524	–	0.868	0.524	0.529
50	0.641	0.387	–	0.641	0.387	0.391

Table F3 Continued on Next Page

Table F3 Continued

Conductor size mm <sup>2</sup>	Solid (Class 1)			Stranded (Class 2)		
	Aluminum	Copper		Aluminum	Copper	
		Uncoated	Coated		Uncoated	Coated
70	0.443	0.268	–	0.443	0.268	0.270
95	0.320	0.193	–	0.320	0.193	0.195
120	0.253	0.153	–	0.253	0.153	0.154
150	0.206	0.124	–	0.206	0.124	0.126
185	0.164	–	–	0.164	0.0991	0.100
240	0.125	–	–	0.125	0.0754	0.0762
300	0.100	–	–	0.100	0.0601	0.0607
400	–	–	–	0.0778	0.0470	0.0475
500	–	–	–	0.0605	0.0366	0.0369
630	–	–	–	0.0469	0.0283	0.0286
800	–	–	–	0.0367	0.0221	0.0224
1000	–	–	–	0.0291	0.0176	0.0177

Note: For temperature correction factors see Table F4.

Table F4  
Temperature Correction Factors,  $k_t$ , for Conductor Resistance to Correct the Measured  
Resistance at  $t^\circ\text{C}$  to  $20^\circ\text{C}$   
(See Table F3.)

Temperature of conductor at time of measurement, $t^\circ\text{C}$	Correction factor, $k_t$
5	1.064
6	1.059
7	1.055
8	1.050
9	1.046
10	1.042
11	1.037
12	1.033
13	1.029
14	1.025
15	1.020
16	1.016
17	1.012
18	1.008
19	1.004
20	1.000
21	0.996
22	0.992
23	0.988
24	0.984
25	0.980
26	0.977
27	0.973
28	0.969
29	0.965
30	0.962

Table F4 Continued on Next Page

Table F4 Continued

Temperature of conductor at time of measurement, t°C	Correction factor, k <sub>t</sub>
<b>Note:</b> The values of correction factors k <sub>t</sub> in the Table are based on a resistance-temperature coefficient of 0.004 per °C at 20°C.	

**Table F5**  
**Closest AWG or kcmil Size(s)**  
**(See Clause F4.)**

Metric conductor size, mm <sup>2</sup>	Closest AWG or kcmil size(s) for selection of insulation and jacket thickness requirement
2.5	14
4	12
6	10
10	8
16	6
25	4
35	2
50	1/0
70	2/0
95	3/0
120	250
150	300
240	500
300	600
400	800
500	1000
630	1250
800	1500
1000	2000

**Note:** This table is provided to permit the correct selection of insulation and jacket thickness requirements, which are dependent on conductor size; however, at the time of publication, the CEC, NOM-001-SEDE, and NEC do not provide ampacity values for the metric conductor sizes shown above.



**Annex G (informative)**  
**Evaluation of Materials Having Characteristics Differing from Those in Table 11**

(See Clause 4.2.5.3.)

G1 The listing of materials resulting from innovation, based upon the 150-day aging and other tests as described in Clause 4.2.5.3, will normally generate proposals to change, or create additions to, certain requirements of the standard, typified by:

- a) Retention of short-term tensile strength and of elongation after accelerated aging in an air oven (see Table 11);
- b) Addition to the materials referenced in 4.2.1.

## Annex H (informative) French and Spanish Translations and Markings

(See Clauses 6, 7.2.4, 7.3.1, and 7.3.2.)

### H1 General

The following alternative markings to those specified in the Standard are optional for products intended for use in specific national applications.

### H2 Markings on wire

	English	Spanish	French
GRD	GROUNDING ONLY	SOLO TIERRA	MISE À LA TERRE SEULEMENT
–	SUBMERSIBLE PUMP CABLE	CABLE BOMBA SUMERGIBLE	CÂBLE POUR POMPE SUBMERSIBLE

### H3 Markings on packaging

<u>English</u>	<u>Spanish</u>	<u>French</u>
SUBMERSIBLE PUMP CABLE	CABLE BOMBA SUMERGIBLE	CÂBLE POUR POMPE SUBMERSIBLE

For Wiring Only Between Equipment  
Located at Water Well Heads and  
Motors of Installed Deep-Well  
Submersible Water Pumps

Uniquement pour le câblage entre les  
appareils situés à la tête des puits  
d'eau et les moteurs des pompes  
immergées pour puits profonds  
installées.

**Superseded requirements for  
the Standard for  
Thermoplastic-Insulated Wires and Cables**

**UL 83, Fourteenth Edition**

The requirements shown are the current requirements that have been superseded by requirements in this edition. The numbers in parentheses refer to the new requirements with future effective dates that have superseded these requirements. To retain the current requirements, do not discard the following requirements until the future effective dates are reached.

**4.1.4.3 (4.1.4.3) Coated copper conductors**

Each wire in a tin-coated conductor shall comply with the requirements of ASTM B 33 or NMX-J-008-ANCE. Each wire in a lead-alloy-coated copper conductor shall comply with the requirements of ASTM B 189. Overcoating of 2.08 mm<sup>2</sup> (14 AWG), 3.31 mm<sup>2</sup> (12 AWG), and 5.26 mm<sup>2</sup> (10 AWG) stranded copper conductor with a layer of tin or lead alloy shall be optional.

In Mexico, the use of ASTM B 189 is recommended for lead-alloy-coated copper conductors.

**4.4 (4.4) Assemblies that include thermoplastic-insulated single conductors**

When cabled into assemblies (length and direction of lay not specified), single-conductor wires that comply with the requirements in this Standard shall not be considered cables, and do not include overall coverings. An open, skeleton tape or wrap intended only to hold the assembly together shall be allowed. Such assemblies shall be allowed to include other single-conductor wires or cables not covered in this Standard. An assembly shall be without a bare or covered aluminum conductor, but a bare copper conductor – size is not specified – that is coated with tin, a lead-base alloy, or other metal shall be optional. A bare, coated copper conductor shall not be covered. The completed assembly shall meet the following requirements:

- a) Assemblies in which a bare, coated copper conductor is included shall be tested for dielectric voltage-withstand as indicated in Clause 5.23, except that immersion in water shall be for at least 1 h.
- b) Each assembly in which a bare conductor is not included shall either be tested as indicated in Clause 5.23 (1 h or longer immersion) or be spark tested as indicated in Clause 5.22, with each layer in a multiple-layer assembly sparked separately.
- c) Each 2.08 – 8.37 mm<sup>2</sup> (14 AWG – 8 AWG) conductor in an assembly shall be individually tested for continuity after the assembly is completed.

**7.2.4 (7.2.4) Polarity identification of circuit conductors**

Polarity identification of circuit conductors other than the grounding or grounded conductor shall be provided by means of contrasting colors other than white, natural gray, or green; by ridges; by stripes; or by word printing. Grounded circuit conductors shall be colored white or natural gray, or shall have white stripes. The equipment-grounding conductor shall be colored green or green with yellow stripes.

In the case of a flat cable that includes an insulated equipment-grounding conductor, the grounding conductor shall be identified as such, either as indicated in this clause or by means of legible, durable ink printing of the words "GROUNDING ONLY", or an equivalent wording, on the outer surface of the finished conductor.

No Text on This Page